



Guide to

# **ELF Systems**

---

**A New Era  
in Bass Reproduction**

Version 1.3W

**COPYRIGHT MODULAR SOUND SYSTEMS, INC. 1997**

Published by Modular Sound Systems, Inc. P. O. Box 488 Barrington, IL 60011

Voice 847 382 4550 Fax 847 382 4551

[www.bagend.com](http://www.bagend.com)

ELF™ and Concealment™ are trademarks of Long/Wickersham Labs

Time-Align®, Time-Aligned™, and Time-Alignment™ are trademarks of E.M.Long Associates

NFM™ is a trademark of E.M.Long Associates

CVR Limiter™ and Bag End® are trademarks of Modular Sound Systems, Inc.

**BAG END**

# TABLE OF CONTENTS

Forward. . . . . 5

## 1. ELF THEORY, MEASUREMENTS, & APPLICATIONS

Introduction. . . . . 6  
The Inventors . . . . . 6  
What is ELF. . . . . 6  
What is a Subwoofer. . . . . 6  
Basic ELF System Connections. . . . . 6  
The ELF Integrator. . . . . 6  
The Low Pass Filter. . . . . 7  
How an Integrator is Different from a Filter. . . . . 7  
The Differentiator / Loudspeaker. . . . . 8  
ELF System Frequency Response. . . . . 8  
ELF System Impedance. . . . . 8  
Why Respond Down to 8 Hertz. . . . . 9  
Blending ELF into Upper Range Loudspeakers. . . . . 10  
ELF Upper Frequency Cutoff and Sensitivity. . . . . 10  
How to Determine ELF Output and SPL Levels. . . . . 10  
Sensitivity Comparisons. . . . . 11  
ELF Concealment. . . . . 12  
ELF Cutoff Frequency for Various Applications. . . . . 12  
    Recording Studios and Mastering Labs  
    Commercial Cinema and Home Theater  
    High Fidelity Home Audio  
    Electric Bass Guitar  
    Electronic Keyboards and Electronic Organs  
    Electronic Drums  
    PA Systems  
    General  
ELF Contour. . . . . 13  
Accurate Reproduction at Soft Levels. . . . . 13  
Stereo Subwoofers. . . . . 13  
Simple Two-Way ELF System Connections. . . . . 13  
Multi-Way Concert ELF System. . . . . 13  
Measurement Techniques. . . . . 14

## 2. REVIEW OF BASIC TYPES OF LOW FREQUENCY LOUDSPEAKERS

Overview. . . . . 14  
Assisted Resonance Systems (ARS). . . . . 14  
Characteristics of ELF and Other Subwoofer Systems. . . . . 15  
Mass Loaded Systems (MLS). . . . . 16  
Electronically Assisted Systems (EAS). . . . . 16  
Conclusions. . . . . 16

# FORWARD

The problems encountered by anyone who has tried to reproduce tight, clean, realistic sound in the bass range are not trivial. The bass range presents the most difficult performance requirements for a sound reproducing system. One reason why the bass range is so important is that it contributes more to the sense of loudness than any other part of the sound spectrum. It provides the foundation upon which the total quality of the sound rests. When the bass is solid and realistic the resultant sound is usually perceived as being very good to excellent: when it is weak and ill-defined, the perceived quality suffers, even if the rest of the audio range is reproduced with great clarity and definition.

**Edward M. Long**

Theory to characterize ported loudspeaker systems and optimization utilizing high order alignments have led to the availability of designs which have significantly improved low frequency response. Unfortunately the cost has been deterioration of the phase response and the consequent smearing of the arrival times of these now audible low frequency sound components. With the ELF technique we do not degrade the phase response while extending the frequency response.

**Ronald J. Wickersham**

E  
L  
F  
4  
G  
U  
I  
D  
E

ELF is a fundamentally new approach to an old problem of accurately reproducing bass frequencies. This guide is intended to explain and share with you some of the work done in this technology to date.

The measurements in this guide were performed with a TEF-20 in a reasonably controlled environment and a great effort has been made to make the most meaningful measurements possible within the scope of the instrument's ability. The fundamental reality of how and why an ELF system sounds correct to the ear is extraordinarily difficult to measure and express with total precision. The very concept of the different measuring techniques and underlying mathematical formulas of the instrumentation itself, used to perform the measurements, is not universally agreed upon, and work in these areas continues by the most advanced minds of today. The simple measurements found in this guide do however highlight some basic differences inherent in the ELF approach and we do draw conclusions based upon the measurements, the theory behind ELF, and our listening experiences. We continue to work in this area and invite review, comments, and suggestions in our pursuit of meaningful ELF measurements and explaining the benefits of the ELF approach ever more precisely.

**James P. Wischmeyer**

## SECTION 1

### WHAT IS ELF

ELF is an acronym for “Extended Low Frequencies”. It is a fundamentally different approach to reproducing bass frequencies from a loudspeaker by extending the low frequency range farther down and with greater accuracy than has ever been done before. In the larger historical view of audio developments, the ELF technology represents as significant a contribution to low frequency sound reproduction as the introduction of the acoustic suspension principle over 40 years ago by Edgar Villchur in 1953.

Although ELF has, at first, found its way into many large and highly visible applications, the basic ELF technology applies to “all” types of audio systems. We have designed this guide with the hopes of addressing this wide variety of applications and interest levels ranging from the audio professional to the home enthusiast.

ELF systems are currently in use in a number of performing arts centers, portable concert reinforcement systems, musical instrument systems, professional recording studios and homes.

### THE INVENTORS

The ELF inventors, Ron Wickersham and Ed Long, well known in the audio field, are responsible for some of the most significant audio breakthroughs of the past several decades, including Time Align® Loudspeakers, Near Field Monitors™ and PZM® Microphones.

### WHAT IS A SUBWOOFER

A subwoofer is a term given to a loudspeaker that is made to operate in the lowest audio range, typically from 80 or 100 Hertz down as far as the design will allow. Response to 20 Hertz is often the ambitious goal of the larger conventional subwoofers, but is seldom realized. Recently there is more and more interest in adding subwoofers to audio systems because adding these subwoofer low frequency capabilities to a system adds a feeling of power and quality to the system. ELF type subwoofers offer realism and musical richness as well as the feeling of power, even when the music, instrument, or voice is not thought to have significant content in the range of the subwoofer.

## BASIC ELF SYSTEM CONNECTIONS

The ELF technology, when applied to a low frequency loudspeaker system, is referred to as a subwoofer system. It requires a separate power amplifier channel dedicated to powering the ELF loudspeaker. An ELF electronic unit is required to drive the power amplifier input. This electronic unit may have various features but at its heart is the “integrator”, the circuit that makes it uniquely ELF.

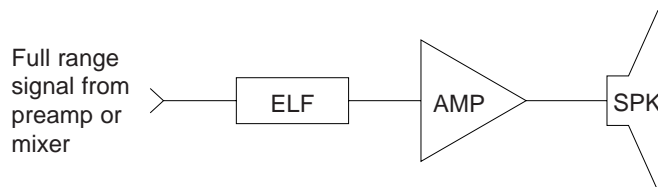

Fig 1. Simple view of ELF system connections.

No connection is required from the amplifier output back to the ELF integrator. This feedback connection sometimes used by other designs is not required with ELF because the ELF system relies on a loudspeaker operating below resonance where the loudspeakers behavior is predictable and uniform. The ELF electronics can control and protect the loudspeaker without the use of sensing devices or monitoring the amplifier's output.

ELF technology allows multiple amplifiers and loudspeakers to be operated from a single ELF integrator unit.

**IMPORTANT:** For best results the input to the ELF integrator should be a full frequency range signal and not a low pass filtered signal as may sometimes be available when connecting into various systems.

### THE ELF INTEGRATOR

An integrator is a common electrical circuit widely used internally in electronic devices. In its basic form it consists of an op-amp with a capacitor in series with the feed back loop. The resistor in parallel with the capacitor is to keep the integrator from trying to integrate to too low a frequency where the circuit will overload due to DC voltage offsets of the op-amp.

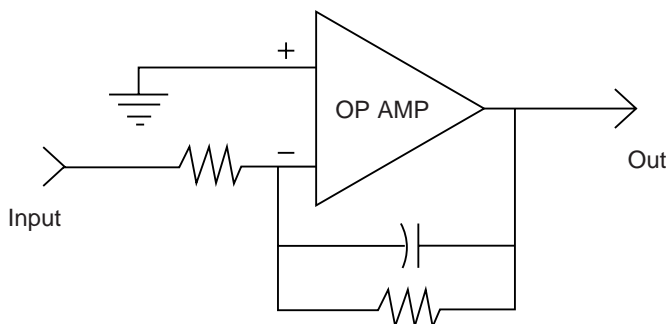

Fig 2. Simple diagram of an integrator.

The frequency response of this circuit rises at a rate of 6 dB per octave as the frequency is decreased. The ELF circuit uses two integrators in series resulting in a 12 dB per octave rise as frequency is decreased. This is the ELF dual integrator, although sometimes referred to as just the ELF integrator. An integrator has uniform phase shift with respect to frequency. A single integrator has 90 degree of phase shift and a dual integrator has 180 degree of phase shift.

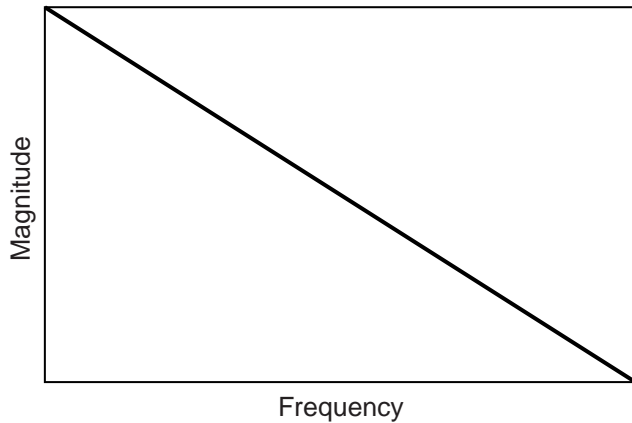

Fig 3. Theoretical frequency response of a dual integrator.

E  
L  
F  
6  
G  
U  
I  
D  
E

Integrator  $e_o = k \int e_1 dt$

dual integrator  $e_o = k \iint e_1 dt$

$e_1$  = input signal

$e_o$  = output signal

$t$  = time

$k$  = constant (determined by circuit component value)

The mathematical response of an integrator will continue to raise the level as the frequency is lowered all the way down to DC, where the gain is infinite (see fig.3). Of course, you cannot build an integrator that integrates down to DC but in some specialized applications (such as astronomy and nuclear physics) liquid helium cooled integrators are operated very close to DC providing very high gain for amplifying very small signals. The ELF-1 integrator will integrate to about 2 Hertz and there is an 8 Hertz filter added to protect the system.

This simple idea “a dual integrator” has never before been used in this way in conjunction with a loudspeaker.

## THE LOW PASS FILTER (conventional approach)

All conventional systems use low pass filters to roll off the high frequencies from the bass loudspeaker driver. This low pass filter is one half of the crossover between the low to mid frequencies. This is a most basic and common aspect of all non ELF systems. All low pass filters introduce, by their very nature, frequency dependent phase shift. The phase shift introduces a significant signal delay which is added to the sound, and this delay can make the bass appear to come later than the upper range sound. This explains why conventional systems sound like the lowest frequencies are coming from very far behind and not connected musically.

## HOW AN INTEGRATOR IS DIFFERENT FROM A LOW PASS FILTER

The main difference between an integrator and a low pass filter is in the total system delay presented to the listener by the electronics shaping its response. An integrator/loudspeaker combination has short and uni-

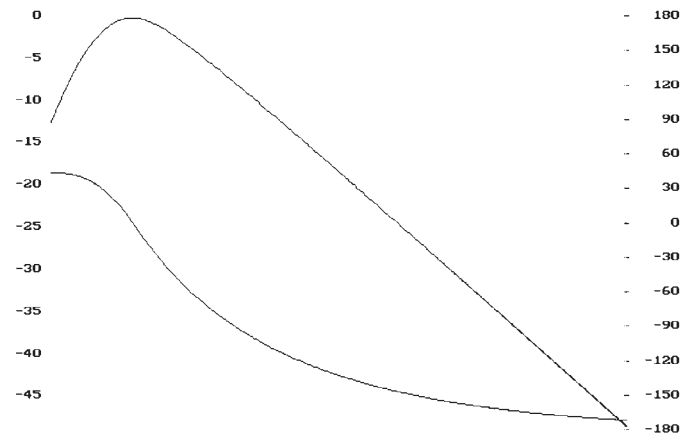

Fig 5. Frequency and phase response of the ELF dual integrator.

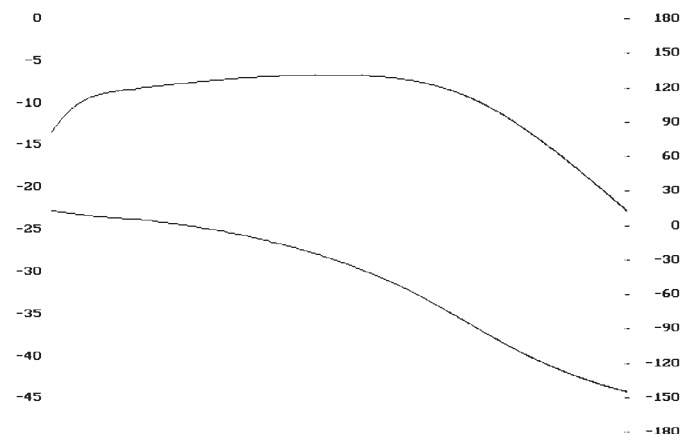

Fig 6. Frequency and phase response of an 80 Hertz low pass filter.

form signal delay and a low pass filter/loudspeaker combination has long and variable signal delay, which becomes longer as the low pass filter cutoff frequency is reduced.

All conventional subwoofer systems use a low pass filter to remove the high frequencies from the loudspeaker. A passive crossover can be used between the power amplifier and the loudspeaker, or an electronic crossover can be placed before the power amplifier. The result is the same either way with the low pass filter adding considerable phase shift and therefore delay which increases as the filter cutoff frequency is reduced.

The ELF subwoofer system uses the ELF integrator to extend the low frequency response and to remove the high frequencies from the loudspeaker. This frequency and phase response of the integrator is complementary to both flatten the loudspeakers response below resonance and correct the phase response in the right direction to produce a short and fixed total signal delay of the system.

The actual time offset is small and fairly constant and reasonable to physically align. The graph in figure 5 shows the frequency response and phase response of the integrator. The flatter phase line on the right is the phase response of the integrators and the phase shift rise (increase in phase shift and therefore delay) on the left is the 8 Hertz hi pass filter used to roll off the rising integrators. The effect of the filter can be seen to a diminishing degree all the way to the upper range on the right. Compare this to the frequency and phase response of the low pass filter in figure 6.

The important and noteworthy aspect of these two graphs is the amount and direction change in the phase response.

$$\text{differentiator } e_0 = k \frac{d e_1}{d t}$$

$$\text{dual differentiator } e_0 = k \frac{d^2 e_1}{d t^2}$$

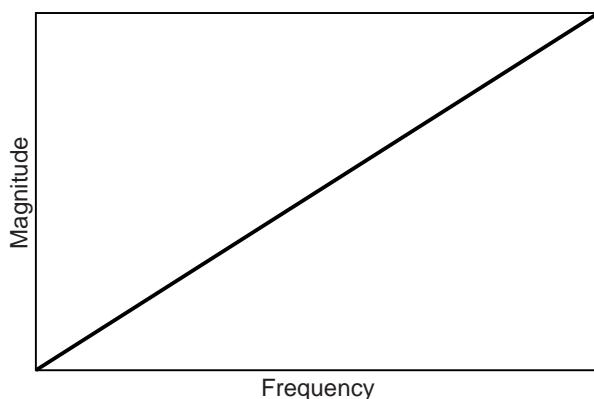

Fig 8. Theoretical response of a dual differentiator.

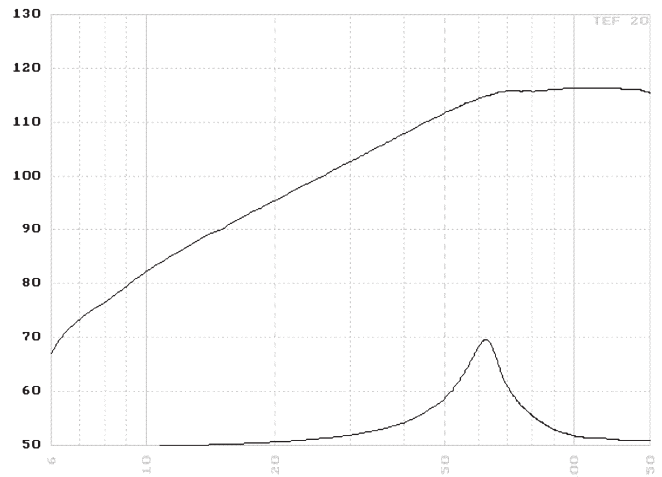

Fig 9. Typical response of a loudspeaker in a sealed enclosure.

## THE DIFFERENTIATOR / LOUDSPEAKER

A loudspeaker by its very nature, when operating below its resonance inside a sealed box, responds as a dual differentiator. This very predictable behavior below resonance is the key to the ELF system.

The mathematical response of a dual differentiator will continue to raise the level by 12 dB per octave as the frequency is raised all the way up to infinite frequency, where the gain is infinite too. Of course, you cannot build a differentiator that does this, but below resonance a loudspeaker follows this behavior precisely.

In figure 9 an EL-18 Loudspeaker in a 3 cu ft sealed box is measured in half space. The 12 dB/octave roll off below resonance is typical of a loudspeaker in a sealed box.

## ELF SYSTEM FREQUENCY RESPONSE

The acoustical response of the ELF system is a combination of the ELF integrators response and the loudspeaker in the enclosures response.

## ELF SYSTEM IMPEDANCE

It can further be seen in Figures 11 and 12 that the impedance of the ELF loudspeaker is uniform below resonance. Figure 12 shows at resonance the frequency response is already 1 or 2 dB down and is rolling off above. Below resonance the uniform load presented to the amplifier is an ideal load for the amplifier to drive. Contrast this to the wild impedance curves presented to amplifiers by conventional ARS systems. (Assisted Resonance System or any bass cabinet which uses both the front and rear radiation of the speaker, ie. any ported enclosure) Since any system wants to favor the notes around its resonant frequency, the ELF minimizes this by having its response begin to roll off just before resonance.

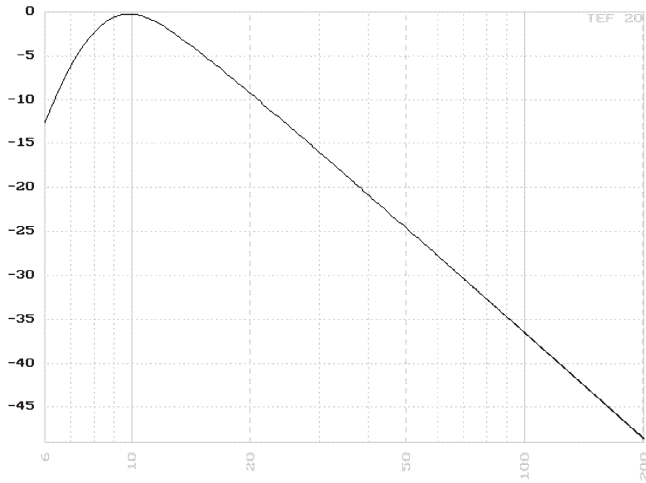

**Figure 10.** Shows the electrical response of the ELF output of the Bag End ELF-1 set to full low frequency bandwidth of 8 Hertz.

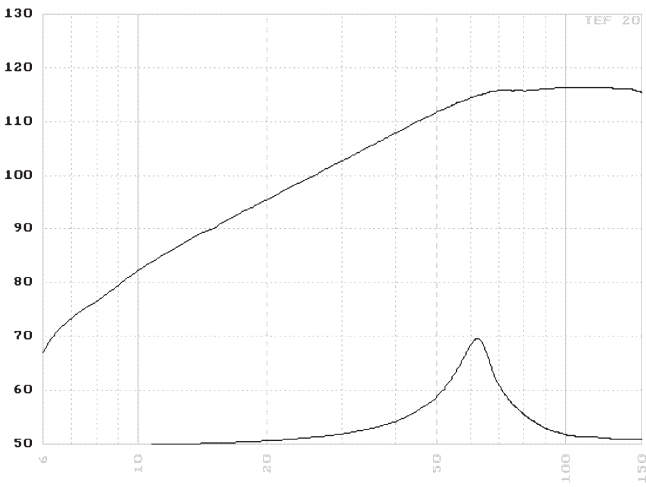

**Figure 11.** Shows the acoustical response of the Bag End S18E loudspeaker system measured in half space.

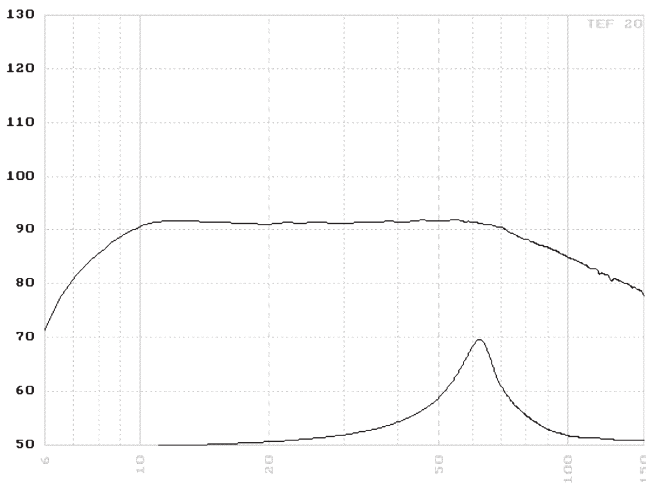

**Figure 12.** Shows the total acoustical response of the ELF-1 dual integrator combined with a S18E loudspeaker system measured in half space.

It has been known for many years that transducers do not perform well with resonances within their operating range. This is well understood by designers of other transducers such as microphones, phono cartridges, hi frequency drivers, etc. Yet most non ELF bass system designs include one or more resonances right in the middle of their operating range. This causes the system to favor playing the notes around resonance. It is not possible to equalize away the tendency to favor the frequencies around resonance and reproduce them equally with the other frequencies.

With the uniform ELF impedance, and operating below resonance, each note is reproduced evenly and with the same emphasis, not favoring any particular frequency.

### WHY RESPOND DOWN TO 8 HERTZ

Why respond down to 8 hertz? The answer is simply because the sonic quality throughout the audible bass range is improved by extending the frequency response, and thus flattening the phase response, to the highest degree possible.

The ELF is a no compromise technology with an inherently great degree of flexibility. By extending the frequency response down a full octave below what is considered to be the lowest musical note, low C on a pipe organ (16 Hz), we improve the phase response and thus reduce the delay throughout the entire audible bass range. This excellent phase response and inherently short signal delay is why subjectively the ELF system is known for its quick, tight, and musically connected bass sound throughout the entire bass range, not just the lowest frequencies. With its good phase response as well as its extended frequency response it

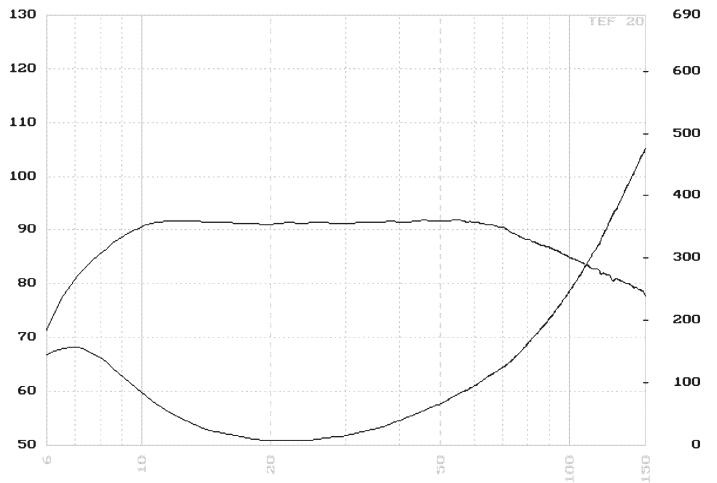

**Fig. 13.** Frequency & Phase of ELF speaker.

can much more accurately represent the actual recording or the character of the sound being fed into the system than conventional designs and their long signal delays.

In figure 13 the frequency and phase response of the ELF-1 with the S18E loudspeaker system measured in half space shows the 6 dB down point at 90 Hertz with a phase shift of 180°. The receive delay setting on the TEF is 20.7 ms.

## BLENDING AN ELF SUBWOOFER INTO THE UPPER RANGE LOUDSPEAKERS

At Bag End, and through a variety of our associate testing sites, we have been listening, learning, measuring, and designing ELF systems for over 10 years. For those of you without an acoustical laboratory or extensive test equipment it will be reassuring to know that with a little practice and your good ears you will be able to match up any ELF subwoofer to any upper range system without extensive measuring equipment. We, and others, have done this by listening and afterward we verified our settings with measuring equipment and found they measured correctly as well. ELF improves your ear's ability to quickly and accurately adjust the

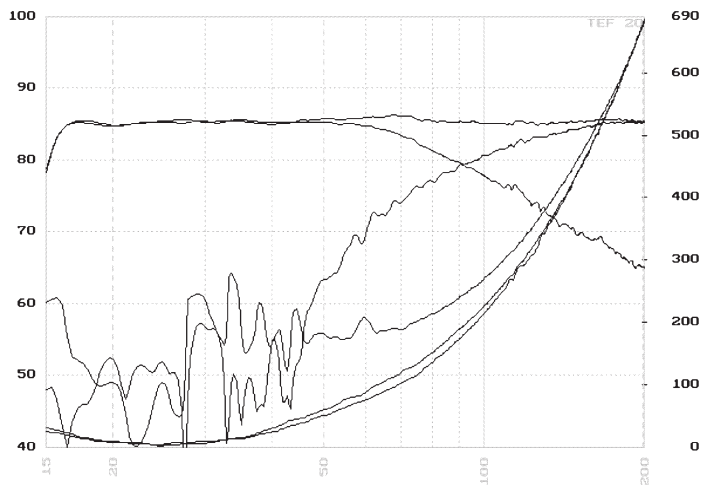

Fig. 14.

relative level between the subwoofer and the upper range system. If you have instrumentation this combined response is easy and interesting to measure.

In Figure 14 it can be seen that the frequency response is +/- 0.5 dB from below 20 Hz to above 200 Hz. The crossover frequency is 6 dB down from the combined response as it should be. The phase of the two sections follow closely (as you would expect for a 6 dB down crossover point) and each section adds correctly to produce a flat frequency response.

Figure 14 shows frequency response and phase response of an S18E and a TA12 loudspeaker system

both individually and their combined response measured in half space. This acoustical blend is achieved with the ELF-1 settings as follows:

- High pass frequency. . . . .120 Hz
- High pass gain. . . . .unity
- High pass polarity. . . . .+
- ELF cutoff. . . . .8 Hz
- ELF gain. . . . .+8 dB
- ELF polarity. . . . .-

When using S18E ELF enclosures these settings are recommended as a good starting point. The relative gain between ELF and the High Pass output will need to be adjusted for the quantity and type of loudspeakers used.

The 120 Hz filter is -3 dB at 120 Hz. The -3 dB point is an accepted standard way to specify filters so we use this method, but it should be noted that what is actually required is a -6 dB crossover point when coherent acoustical addition is occurring. To determine the -6 dB frequency, multiply the -3 dB frequency by 0.75.

As the upper limit of the ELF system is determined by the system resonance and significantly by the box size, the high pass filter frequency setting required will change with different ELF loudspeaker models.

**Note:** The + polarity on the high pass section and the - polarity on the ELF section on the ELF-1 will both produce a positive asymmetrical output at crossover when a positive asymmetrical input is fed into the ELF-1.

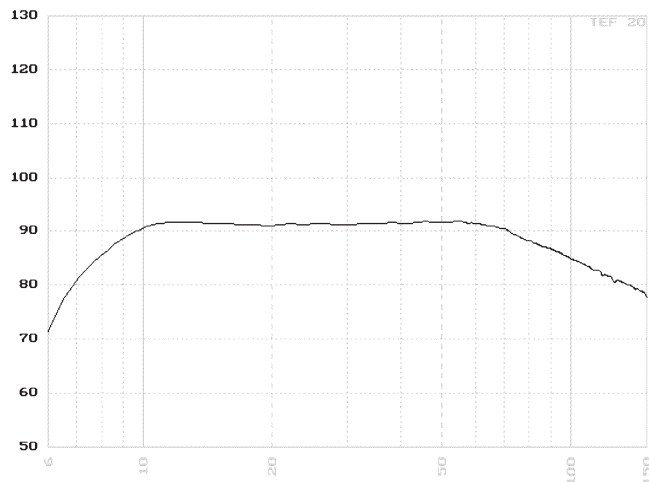
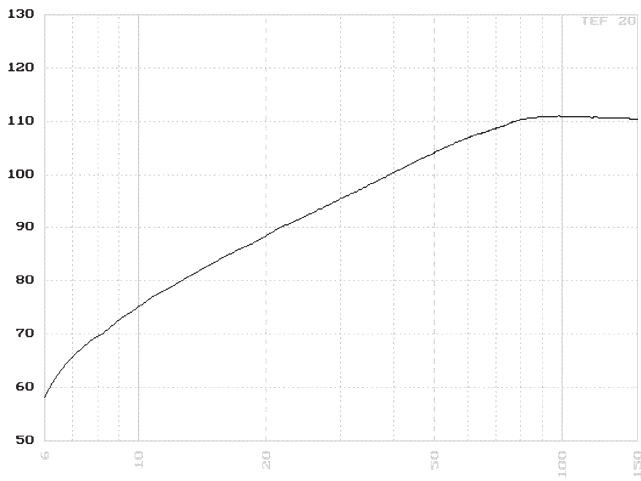

Fig. 15. Shows our S18E loudspeaker system with ELF integration.

## ELF UPPER FREQUENCY CUTOFF

The upper response of an ELF system is primarily determined by the system resonance which is determined by the stiffness of the air in the enclosure and by the moving mass of the driver cone and voice coil



**Fig. 16** EL-10 in S10E enclosure dB calibrated to dBSPL. Input signal 28V. (100 watts)

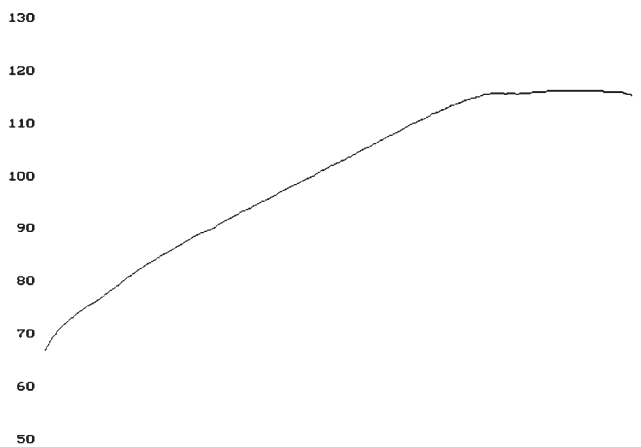

**Fig. 17** EL-18 in S18E enclosure dB calibrated to dBSPL. Input signal 28V. (100 watts)

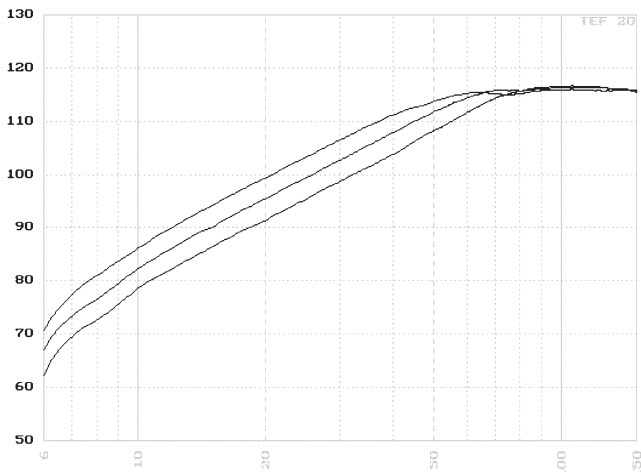

**Fig. 18.** EL-18 in S18E-LT (2 ft<sup>3</sup>), S18E (3 ft<sup>3</sup>), and a sealed S18B (6 ft<sup>3</sup>) enclosures dB calibrated to dBSPL. Input signal 28V. (100 watts)

assembly. We have chosen a 3 cubic foot enclosure for our standard S18E enclosure with an upper limit of -6 dB at 90 Hertz as shown in figure 15. Several additional enclosure sizes are offered or can be built to produce a wide variation of upper cutoff frequencies with the corresponding change in overall efficiency.

## HOW TO DETERMINE ELF OUTPUT SPL LEVELS

The ELF SPL output level is best determined by looking at a calibrated frequency response graph and determining the SPL level at the frequency of interest. As the level changes with frequency, a single number is not useful for design and comparison to other systems. The most power is required at the lowest frequency, therefore

you may calculate the power and number of drivers required for the lowest frequency desired by simply referring to a calibrated frequency response graph for the specific driver and enclosure combination as shown in figure 16, 17, or 18.

Figure 17 and 18 show first the EL-18 in a 3 cubic foot enclosure and then in comparison of 2, 3, & 6 cubic foot enclosures. It can be seen that the larger the box and thus the lower resonance (and lower high frequency cutoff point when integrated) also naturally adds level to the system and thus a system designer has the additional design tool of trading off the upper crossover point and

smaller cabinet size with output level. The higher the upper crossover frequency the less sensitive the system will be and the lower the upper crossover frequency the more sensitive it will be. With this trade off in sensitivity all designs will play to an equally low frequency.

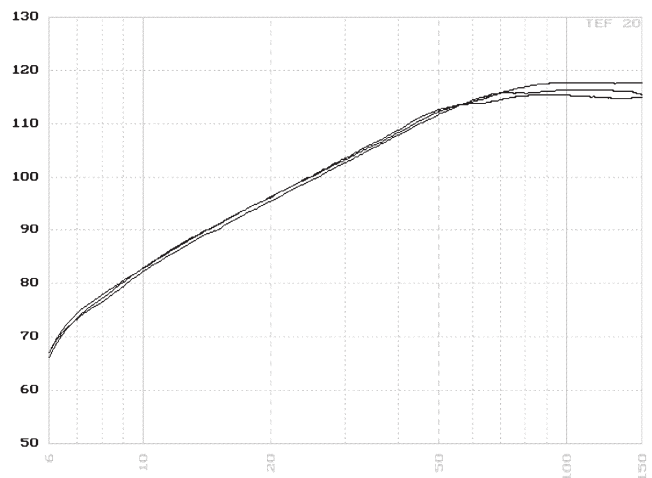

**Fig. 19** Sensitivity comparison of 3 loudspeakers.

## SENSITIVITY COMPARISONS

The mid-range sensitivity ratings of bass drivers supplied by many loudspeaker manufacturers may not be a useful specification for determining the actual performance of the loudspeaker in the low frequency region. Many companies, as of this date, rate low frequency drivers above 100 Hertz. This specification may not be as useful in determining the actual performance of a subwoofer system in its main operating range of 20 to 100 Hertz.

Our method to determine sensitivity is to place the loudspeaker in a sealed box, specify the box volume, measure the sound pressure level at a specific distance, (1 meter) using a specified voltage input, at a specified frequency, into the known impedance, in a half space environment.

Shown in figure 19 are three 18" drivers with their frequency response curves overlaid. Measurements were taken in a half space environment throughout the entire frequency response range of the measurement. The measurements were taken on the same day in the same box and with the same equipment and test signal.

It can be seen by the frequency response curves that the sensitivity in the bass range is within one dB, yet above resonance the levels have more variation. Two of the three speakers tested, were made by other high quality U.S. speaker manufacturers, each have similar sensitivity ratings in their specifications and are generally accepted as the highest sensitivity 18" drivers available. The 3rd speaker in this comparison is the Bag End EL-18 driver.

Generally speaking, the efficiency of ELF when compared to ARS (Assisted Resonance System) designs allows one to say that in a narrow frequency range the ARS system is louder or more efficient, but not over the entire bass range and the ARS efficiency is obtained at the cost of degrading the sound quality. Roughly speaking, for an ELF design to equal the output of a conventional ARS ported design, in the narrow range of the port's efficiency, you will need a little more ELF cone area and/or more power, but the actual total internal volume of the cabinets will be considerably less. In addition, the ELF design will respond more evenly, go lower, and sound much better. So it may take a little more power for ELF to equal the output of an ARS in the narrow range of its port's resonance, but with a smaller cabinet size.

Generally and subjectively speaking, the ELF bass from a pair of S18E enclosures will have a very pleasant sound with tight, low bass and be very musical sounding. It does not have the loud boom in the upper bass range often found in vented systems. Once you become accustomed to the precision of ELF sound there is no turning back to a non ELF system.

## ELF CONCEALMENT™

It is preferable to install sufficient loudspeakers and amplifiers to reproduce the sound level required. When the system is limited in capacity or an unexpectedly large signal is present, concealment is a type of protection circuit with a very musical and pleasant way of sounding even when well beyond its protective threshold. It is not part of the ELF dual integrator itself but an

additional complementary ELF technology, providing absolute protection in a natural and musical way and actually concealing the fact that it is protecting the system. The ELF concealment performs dynamic control of reducing the low frequency extension. It will allow the system to play with the upper bass notes unaffected while protecting the system from overload caused by playing the lower notes louder than the amplifier and/or loudspeaker can reproduce safely and undistorted. It is very important that the concealment threshold is set to the correct level for it to function correctly and prevent amplifier clipping and/or speaker overload. For general non critical studio applications it is very acceptable for the concealment threshold light to flash intermittently but if it stays on to full intensity it means that you either have the threshold set too low or, if the threshold is set properly, that you require additional speakers and amplifiers for your application. For critical studio and mastering lab monitoring applications the concealment threshold should not be crossed as this will reduce your ability to hear what is actually being recorded. In addition, when the concealment threshold is crossed, it is changing the frequency response down low and degrading the phase response both at the lowest frequencies and into the middle bass range as well.

## ELF CUT OFF FREQUENCY AND VARIOUS APPLICATIONS

For certain applications you may not want to operate the system down to 8 Hertz. The low frequency limit may be adjusted by selecting an appropriate ELF cutoff frequency. The phase response is degraded by cutting off the frequency response at a higher frequency. This is a reasonable compromise as this higher cutoff may be needed, for example, to filter out the low frequency rumble (concert hall noise, air conditioning, etc.) commonly found on many of today's CD recordings.

### Recording Studios and Mastering Labs

When utilizing ELF in recording and mastering playback applications, the 8 Hertz response will insure proper treatment of the full spectrum. In addition, you should always note when concealment is taking place and not perform your final mix past the concealment threshold of your ELF system. With the popular trend of adding subwoofers in homes and theaters, the low frequency problems found on CDs and other recordings will need to be corrected in the recording and mastering stages so that the full benefits of a wide band response can be realized in the playback.

### Commercial Cinema and Home Theater

When utilizing ELF for cinema and home theater systems you may have to raise the ELF cutoff frequency to 20 or 30 Hertz to reduce low frequency noise found on many recordings. Allow the concealment to perform its function and occasionally monitor the concealment by observing the LED indicator.

### High Fidelity Home Audio

When utilizing ELF in a very fine home audio application it should be treated as a studio application. (refer to studio section) In addition, you have the added option of adjusting the ELF cutoff to any higher frequency required above 8 Hertz. This enables you to reduce low frequency noise found on some recordings.

### Electric Bass Guitar

When utilizing ELF for electric bass guitar systems, depending on the instrument, you may have to raise the ELF cutoff frequency to 20 or 30 Hertz to prevent low frequency string handling noise. Allow the concealment to perform its function, and occasionally monitor the concealment by observing the LED indicator.

### Electronic Keyboards and Electronic Organs

When utilizing ELF for electronic keyboard systems, most systems will work well with an 8 Hertz ELF cutoff frequency. Allow the concealment to perform the protection function and occasionally monitor the concealment by observing the LED indicator.

### Electronic Drums

When utilizing ELF for electronic drum systems, most systems will work well with an 8 Hertz ELF cutoff frequency. Allow the concealment to perform the protection function and occasionally monitor the concealment by observing the LED indicator.

### PA Systems

When utilizing ELF for general PA systems, you may have to raise the ELF cutoff frequency to 20 or 30 Hertz to prevent low frequency noise from the microphones. Allow the concealment to perform its function but always monitor the concealment by observing the LED indicator and refer to the concealment section for a thorough understanding of this function.

### General

In general you should allow the ELF hi pass cut off to be set as low as possible without allowing too much low frequency noise into the loudspeakers. Remember you are raising the ELF cut off to improve the sound quality by removing the noise, not to protect the amplifiers and loudspeakers from low frequency damage as the concealment will provide that function.

### ELF CONTOUR

Designed primarily for large arrays, the contour may be used as an additional tool to shape the lower end of the frequency response for any system application. Adding contour will cause a rise in the frequency response just before the low frequency rolls off. The contour occurs just above the ELF cutoff frequency. Long arrays, perhaps 20 to 40 feet, are required for the optimum output and directivity performance of any bass system. These

arrays naturally have more output in the upper bass range due to the gain added by the directivity of the array. At lower frequencies you will not receive this additional gain. Contour will then allow you the option of adding a boost at the lower frequencies to flatten out the total response of the array.

### ACCURATE REPRODUCTION AT SOFT LEVELS

We are still working on documenting exactly why, but it is clear to those familiar with ELF that it is capable of reproducing clear audible bass notes at very low volume levels. One theory is that the conventional ARS (Assisted Resonance Systems) because of the several resonances within the systems range, takes an amount of time for the energy to build up within the system before it "switches on". It may be that part of what is often assumed to be the simple Fletcher Munson loudness curve of the human ear is actually both the Fletcher Munson curve and the characteristics of these common ARS bass speaker designs. You will find the ELF system requires much less, if any, loudness compensation as it is turned down to a whisper.

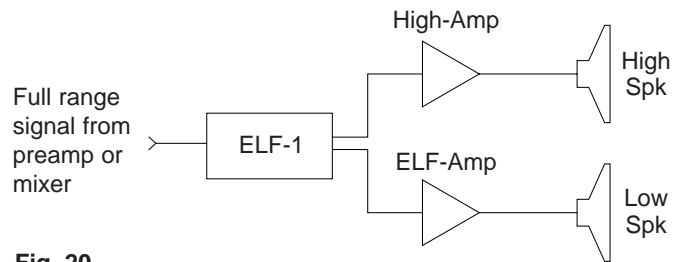

Fig. 20

### STEREO SUBWOOFERS

With ELF, stereo subwoofers in certain applications can become desirable because of the inherent ELF fidelity and precision the source can be perceived to have direction and because the ELF's alignment and musical connection to the upper stereo image is excellent. This may be most effective in larger rooms and outdoors.

### SIMPLE TWO WAY ELF SYSTEM CONNECTIONS

The ELF subwoofer requires a separate power amplifier to operate. This is called a 2-way system or biamping in its simple form. A typical upper range speaker may be a 2-way passively crossovered system such as the Bag End Time-Aligned® TA12 or TA15. The ELF integrator is designed to universally blend an ELF subwoofer into

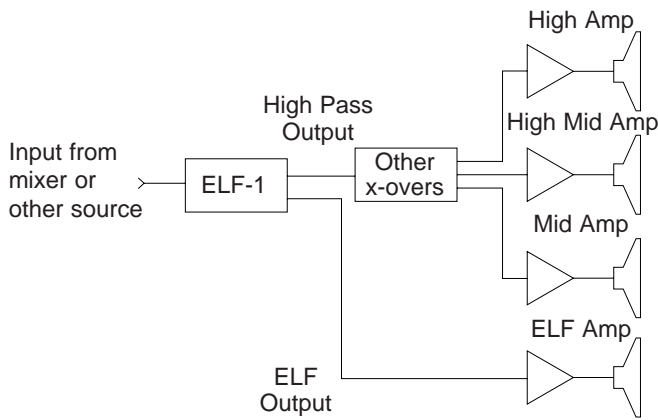

Fig. 21

any other system as well. For passive upper range systems use the connections in Fig 20.

### MULTI-WAY CONCERT ELF SYSTEM

For larger concert systems requiring 3 or 4 way upper range, connect the output of your mixer or final equalizer to the input of the ELF-1 then connect the high pass output of the ELF-1 to the input of your existing electronic crossover as follows in Fig 21.

In concert systems we do not recommend adding the ELF onto a sub group mixer output as it is often done with conventional subwoofer systems. By allowing the lower portion of the upper range to run down into the ELF range it is most likely that you will have a large bump or dip in the upper bass frequency response. The likely resulting poor frequency response and/or poor phase response blend between the ELF and the upper range loudspeakers may cause you to use more overall EQ than otherwise necessary with diminishing returns and reduced ELF benefits.

In addition, the quick response and pleasant sound quality of the ELF will allow you to extend the range of the entire mix and not just a few select channels without the low frequency problems often associated with this approach.

Further benefits are provided by utilizing the high pass section CVR Limiter™ as it is a unique feature of the ELF-1, particularly good sounding, and a design circuit not common to other limiters. See section 4, ELF-1 circuit design description, for additional information on the CVR Limiter.

For large sound systems utilizing large ELF arrays refer to the section on “ELF Contour” for information on contouring long ELF loudspeaker arrays.

## MEASUREMENT TECHNIQUES

When the test space is referred to as “half space” the loudspeaker under measure is buried so that the baffle is flush with level ground at least 100’ feet away from the nearest tree, building, or any obstacle. The microphone is mounted with a small boom stand directly over the loudspeaker at 1 meter from the speaker baffle.

The low frequency tests have a frequency resolution of 2.8 Hertz, unless otherwise specified.

Phase measurements are relative but they do correctly indicate the phase change and/or phase direction within each measurement.

The small additional roll off below 7 Hertz includes the frequency response of the B & K 4007 microphone used.

The test instrument used in these graphs is a TEF-20, a FFT based instrument. We have attempted to minimize the many artifacts present in the TEF measurement process.

## SECTION 2

### REVIEW OF BASIC TYPES OF LOW FREQUENCY LOUDSPEAKER SYSTEMS

#### OVERVIEW

There are two basic types of systems used for producing extended bass response; one is acoustical and the other is electronic. Acoustical systems can be divided further into two general categories: Assisted Resonance Systems (ARS) that rely on wavelength dependent parameters, which require large dimensions, and Mass Loaded Systems (MLS) that are inefficient. ARS include ported passive radiator, tuned chamber and transmission line or labyrinth systems. MLS are generally closed box, stiffness controlled systems. The distinction between these two categories can be blurred if both wavelength dependent parameters and mass loading are combined in a system. Electronically Assisted Systems (EAS) include servo controlled and bass boost types. The problems and limitations associated with these systems are shown in the chart. The ARS and MLS are combined under the heading “NORMAL” and EAS are shown under the heading “SERVO.”

For all systems, the bass driver excursion is greatest at the lowest frequency to be reproduced. For a given diaphragm size, the maximum acoustical output level is limited by the maximum excursion capability of the loudspeaker driver. The excursion in the low frequency

## CHARACTERISTICS OF ELF AND OTHER SUBWOOFER SYSTEMS

SYSTEM TYPE	NORMAL	SERVO	ELF™
Enclosure size	Large	Large	Small
Enclosure weight	Heavy	Heavy	Light
Low pass filter required	Yes	Yes	No
Signal delay varies with design changes	Yes	Yes	No
Separate power amplifier required	No	Yes	Yes
Lowest frequency limited by driver resonance and enclosure volume	Yes	Yes	No
Low frequency output limited by driver excursion and amplifier power	Yes	Yes	Yes
Damping	Variable, poor to moderate. Depends upon driver system design, amplifier internal impedance, and cables because system operates above system resonance	Variable, moderate to good, depends upon system design and quality control because system operates above system resonance	Excellent. Independent of driver, amplifier impedance and cables
Transient Response	Poor due to long time delay of low pass filter and low damping	Moderate due to time delay of low pass filter	Excellent due to short time delay and high damping
Signal Delay	Long and variable depending on frequency of low pass filter used	Long and variable depending on frequency of low pass filter used	Short and fixed integrators used have fixed delay
Time offset from upper range system	Large	Large	Small
Driver cone mass	Usually heavy	Usually heavy	Can be light
Voice coil mass	Usually heavy	Usually heavy	Can be light
Cone area	Depends upon SPL	Depends upon SPL	Depends upon SPL
Cone excursion	Frequency dependent	Frequency dependent	Frequency dependent

part of the range is much greater than at the higher frequencies, in fact, for every halving of the frequency, the excursion is 4 times as great. For example, to produce the same acoustical output at 32 Hz (Low C) as it does at 64 Hz with a 1/8" peak to peak motion, the excursion of the bass driver diaphragm would have to be 1/2" peak to peak. The simplest system, which would be a driver operating in a closed box, is constrained by this law of physics.

### ASSISTED RESONANCE SYSTEMS (ARS)

These excursion constraints led to the development of Assisted Resonance Systems (ARS) in which the

acoustical output is increased beyond the normal limit of the driver excursion by producing acoustical output from a port or multiple ports.

The application of Helmholtz's principles of acoustical resonance was employed to develop ported systems, which in early times were called bass reflex systems. Another type of wavelength dependent system is the transmission line, which in its folded form was called an acoustical labyrinth. Transmission line systems rely on the output from the rear of the loudspeaker driver to assist the output from the front, after passing through a long ducting system inside the loudspeaker enclosure. Transmission line systems are of necessity the largest of the ARS types.

Ported systems have seen recent popularity for a number of reasons. The development of more scientific methods of design, based upon the work of Novak, Thiele, Small, Keele, and others has improved the chances that a design effort will result in a system that behaves as predicted. Ported systems have progressed from simple types to complex, multichamber systems. These latter systems are designed with the loudspeaker driver(s) mounted inside the enclosure and the acoustical output radiated from a single or multiple ports. All of these ARS are large, when they are required to reproduce low frequency sound, because they rely on the acoustical stiffness of the air in the enclosure as well as the mass of the air in the port to tune them to a low frequency. This requirement for large dimensions means that the size and weight of the enclosure is directly a function of the frequency to be reproduced; The lower the frequency the larger and heavier the enclosure must be. The quality of sound produced by ARS is very dependent upon the internal impedance or damping provided by the driving amplifier. The resistance of the connecting cables also can be a significant factor. This latter consideration is very important for systems which require long cable runs from the amplifier to the loudspeaker system.

The variation in impedance of the triple tuned subwoofer is an example of the problem presented to a driving amplifier. Amplifiers work best when the impedance of the load is constant. The interaction of the amplifier's internal impedance and the varying impedance presented to it by the loudspeaker, will affect the amount of power that the amplifier must deliver. It also affects the damping, or tightness of control, that the amplifier can exert upon the loudspeaker system. The upper range response of the system also must be rolled off by a low pass filter. This will introduce a signal delay in the low frequency range because all low pass filters have signal delay. Also, because the rear of the loudspeaker driver diaphragms have no loading at the lowest frequencies, where the ports act merely as vents to the outside of the enclosure, a high pass filter must be added to prevent the loudspeaker drivers from being driven beyond their capabilities and thus produce noise and distortion.

### **MASS LOADED SYSTEMS (MLS)**

This category of system is used for home music systems where efficiency is not very important. The perceived quality of the bass reproduced by many MLS systems is usually booming and under-damped.

### **ELECTRONICALLY ASSISTED SYSTEMS (EAS)**

The most complicated of all the different types of bass reproducing systems is the servo control type. Servo systems are replete with complicated and interacting

parameters which must be monitored and controlled in real time if the system is to work properly. Even the placement of the accelerometer used to monitor the diaphragm motion is not trivial.

### **CONCLUSIONS**

The systems we have examined each have their own particular limitations. The perceived sound quality ranges from poor to acceptable. The size and weight of ARS, the inefficiency of MLS, and the complexity of EAS, were the motivation to find the better technology, ELF.