

SYSTEM COMPONENTS

Enclosure:
3/4" MDF

Transducers:
8" Low frequency cone
1.75" Aluminum compression
high frequency

Input Connectors:
5-way binding posts

Grille:
Black nylon cloth over wood
frame

Optional Hardware:
Wall mount bracket

ACOUSTIC AND ELECTRICAL

System Type:
2-way coaxial, vented 0.54 ft³

Impedance:
8 Ω

Crossover Network:
Passive Time-Align® equalizer
type @ 2.9 kHz

Time Offset Between Drivers:
< ± 25 Microseconds

Frequency Response:
95 Hz to 20 kHz ±3 dB
(4π Steradians)
(Intended for use with an
ELF™ subwoofer)

Sensitivity:
93 dB SPL (1W @ 1m)

Distortion:
Less than 1% THD (95 Hz to
20 kHz 94 dB SPL @ 1m)

Power Handling:
150 W continuous sine wave
600 W instantaneous peak

PHYSICAL

Finish:
Ebony Soft Swade™ urethane

Dimensions:
16.5"h x 12.5"w x 8.5"d
42 cm x 32 cm x 22 cm

Weight:
29 lbs.
13 kg

Shipping Dimensions:
24" x 16" x 14"
61 cm x 41 cm x 36 cm

Shipping Weight:
34 lbs.
16 kg

APPLICATIONS:

Post Production Studio

Film & Video Post Production

Mastering Facility

Home Theater

Home Stereo

MM-8H The MM-8H is an 8-inch, 2-way coaxial, Time-Aligned™ loudspeaker system designed for critical studio monitoring applications and reference-quality home theater systems. When used with a Bag End ELF™ subwoofer, the system achieves a flat frequency response wider than the audible spectrum. It has been designed to maintain its low distortion sound at very high sound pressure levels.

About Time-Align® Time-Align® assures that the fundamental and overtones of a complex, transient, acoustical signal are presented to the listener in the same relationship as the electrical signal at the input terminals of the loudspeaker.

The conventional loudspeaker spreads out the sound in time: when a rapid series of transients occur the results are blurring and lost detail. With Time-Align®, a transient is presented as a tight package of energy, with the same time relationships as the natural sound. This means that a rapid series of transients will be heard clearly.

True Time-Alignment™ requires much more than just physically lining up the loudspeaker components. It requires consideration of the driver placement, driver delay and adjustment of the crossover delay parameters. This achieves the precise simultaneous acoustical arrival time of each driver throughout the crossover region.

Along with state-of-the-art laboratory instruments, the proprietary Time-Align® generator, built by Ron Wickersham, is used in designing our loudspeaker systems. The Time-Align® generator is founded upon different underlying mathematical principles than are used in the more common Fourier based measurement equipment.

When comparing a genuine BAG END Time-Aligned™ speaker system to any other, our additional design work is easy to hear and appreciate. The dramatic clarity, realism, and overall pleasant sound of our Time-Aligned™ loudspeakers is noted throughout the world.

BAG END Loudspeakers
22272 Pepper Road
Barrington, Illinois
60010 USA
Voice 847 382 4550
Fax 847 382 4551
www.bagend.com





MM-8H

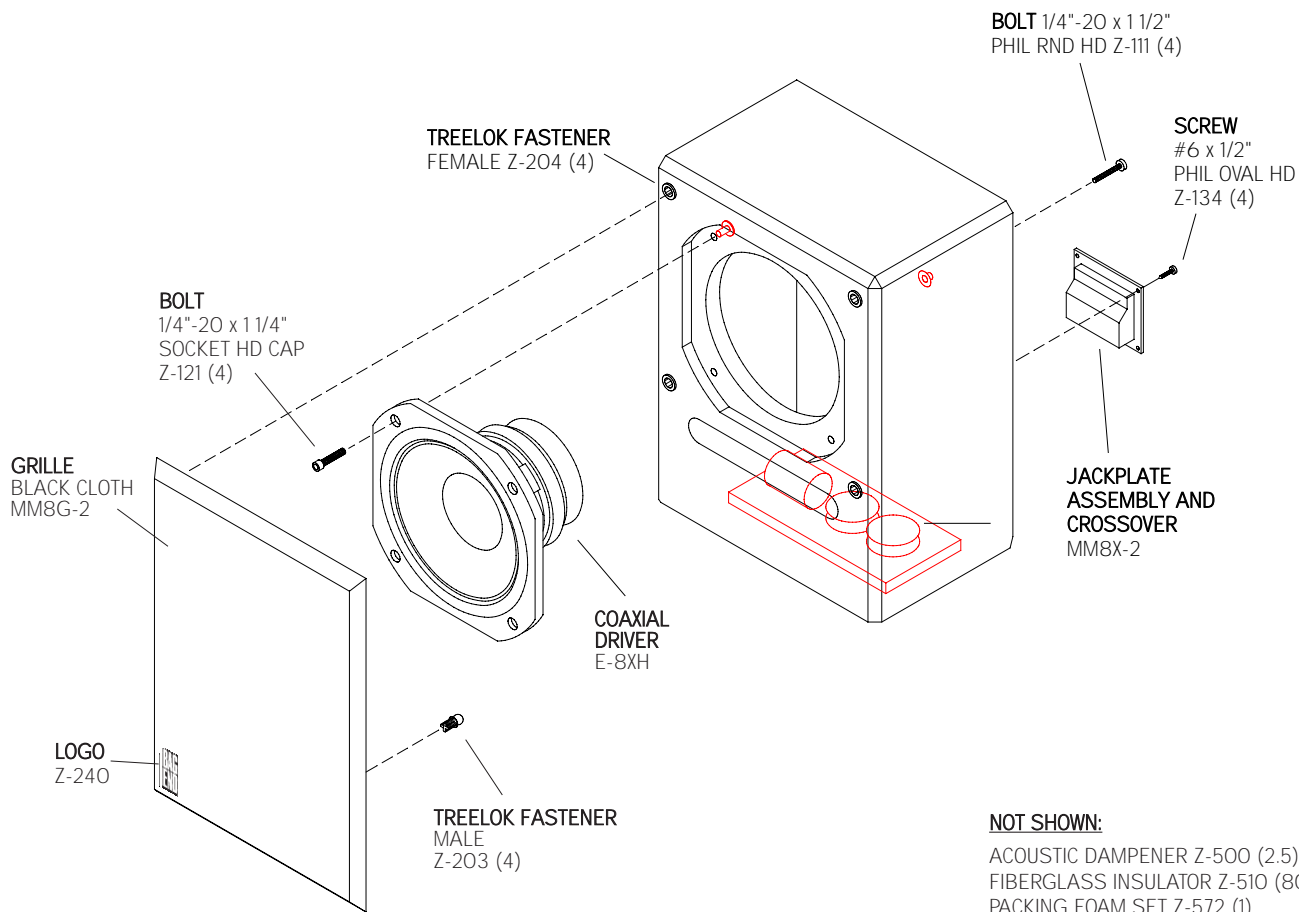

SYSTEM SCHEMATIC

