

BAG END SELF-POWERED P-CRYSTAL-R TIME-ALIGN®

S P E C I F I C A T I O N S



SYSTEM COMPONENTS

Enclosure:

18 mm 13-ply birch plywood
Horizontally arrayable

Low Frequency Transducers:

2 - 12" Cone
3" Voice coil
95 oz. Magnet

High Frequency Transducer:

1.4" Exit compression driver
3" Titanium diaphragm
Elliptic conical horn

Internal Amplification:

1 - Minima One

Grille:

14 Gauge black powder coated perforated steel in an extruded aluminum frame with weather seal

Standard Hardware:

Rigging points
1 - 35 mm Stand adapter
2 - Recessed handles
8 - Machined aluminum speaker mounting clamps

End Caps:

2 - 13-ply birch skid plates with protective UHMW polyethylene bumpers

ACOUSTIC AND ELECTRICAL

System Type:

2-way vented 2.5 ft³

Input:

10k Ω Balanced XLR inputs with loop through

Input CAL Sensitivity: +4 dBu

System Power:

1000 W continuous

Frequency Response:

80 Hz to 18 kHz ± 3 dB
(4 π Steradians)

Hi Pass Filter Frequency

Switchable:
-6dB @ 8 Hz, @ 50 Hz, @ 95 Hz

Dispersion:

55° Horizontal (-6 dB)
40° Vertical (-6 dB)

Crossover Network:

Passive Time-Align® equalizer type @ 1.9 kHz

Time Offset Between Drivers:

< ± 25 Microseconds

Maximum Acoustic Output:

130 dB SPL

LED Indicators:

Green, On
Yellow, System Limit
Red, System Fault or Sleep Mode

AC Power Requirements:

88 Volts Minimum
270 Volts Maximum

PHYSICAL

Standard Finish:

Black Ro-Tex Finish

Dimensions:

39.5" h x 14.5" w x 17" d
101 cm x 37 cm x 44 cm

Weight:

115 lbs., 52 kg

Shipping Dimensions:

20" x 47" x 21"
51 cm x 120 cm x 54 cm

Shipping Weight:

129 lbs., 58.5 kg

APPLICATIONS:

Stadium Sound Reinforcement
Auditorium Sound Reinforcement
Church Sound Reinforcement
Audio Visual Presentations
Nightclub Applications
Portable Sound Reinforcement

MINIMA ONE SELF-POWERED The P-CRYSTAL is a full range, long throw, self-powered loudspeaker system offering high fidelity, high efficiency and high power handling capacity. The P-CRYSTAL is designed for applications where high sound pressure and highly directive long throw capability are required. Units are designed to array for larger systems using ATM Flyware™. The P-CRYSTAL-R includes protective end caps, handles, a stand adapter, and quick-release rigging attachment points. Constructed from 18 mm 13-ply birch plywood and finished in Ro-Tex, the P-CRYSTAL-R enclosure is durable and attractive.

OPTIONAL CUSTOM FINISHES Available in textured white paint or ready-to-stain natural birch for greater versatility in location and aesthetics. Also available in outdoor weather resistant package.

ABOUT TIME-ALIGN® Time-Align® assures that the fundamental and overtones of a complex, transient, acoustical signal are presented to the listener in the same relationship as the electrical signal at the input terminals of the loudspeaker.

The conventional loudspeaker spreads out the sound in time: when a rapid series of transients occur the results are blurring and lost detail. With Time-Align®, a transient is presented as a tight package of energy, with the same time relationships as the natural sound. This means that a rapid series of transients will be heard clearly.

True Time-Alignment™ requires much more than just physically lining up the loudspeaker components. It requires consideration of the driver placement, driver delay and adjustment of the crossover delay parameters. This achieves the precise simultaneous acoustical arrival time of each driver throughout the crossover region.

Along with state-of-the-art laboratory instruments, the proprietary Time-Align® generator, built by Ron Wickersham, is used in designing our loudspeaker systems. The Time-Align® generator is founded upon different underlying principles than are used in the more common Fourier based measurement equipment.

When comparing a genuine BAG END Time-Aligned™ speaker system to any other, our additional design work is easy to hear and appreciate. The dramatic clarity, realism, and overall pleasant sound of our Time-Aligned™ loudspeakers is noted throughout the world.

BAG END Loudspeakers
22N272 Pepper Road
Lake Barrington, Illinois
60010 USA
Voice 847 382 4550
Fax 847 382 4551
www.bagend.com





P-CRYSTAL-R

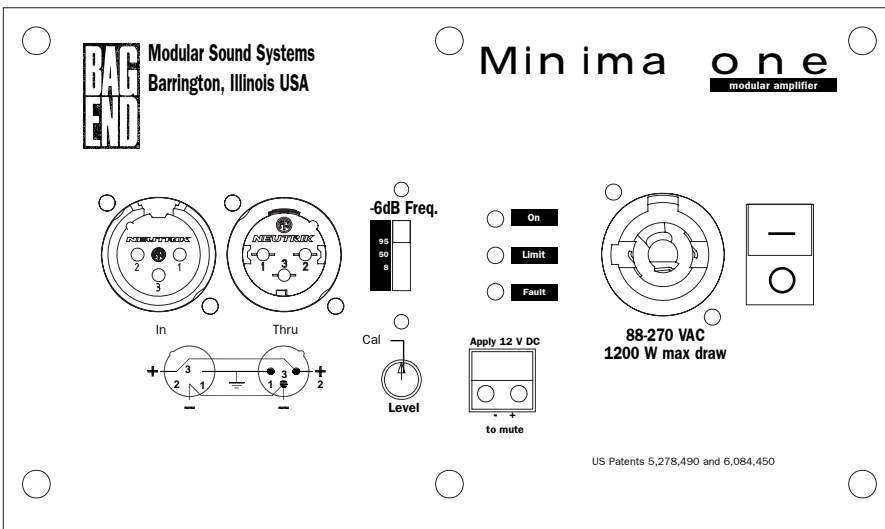
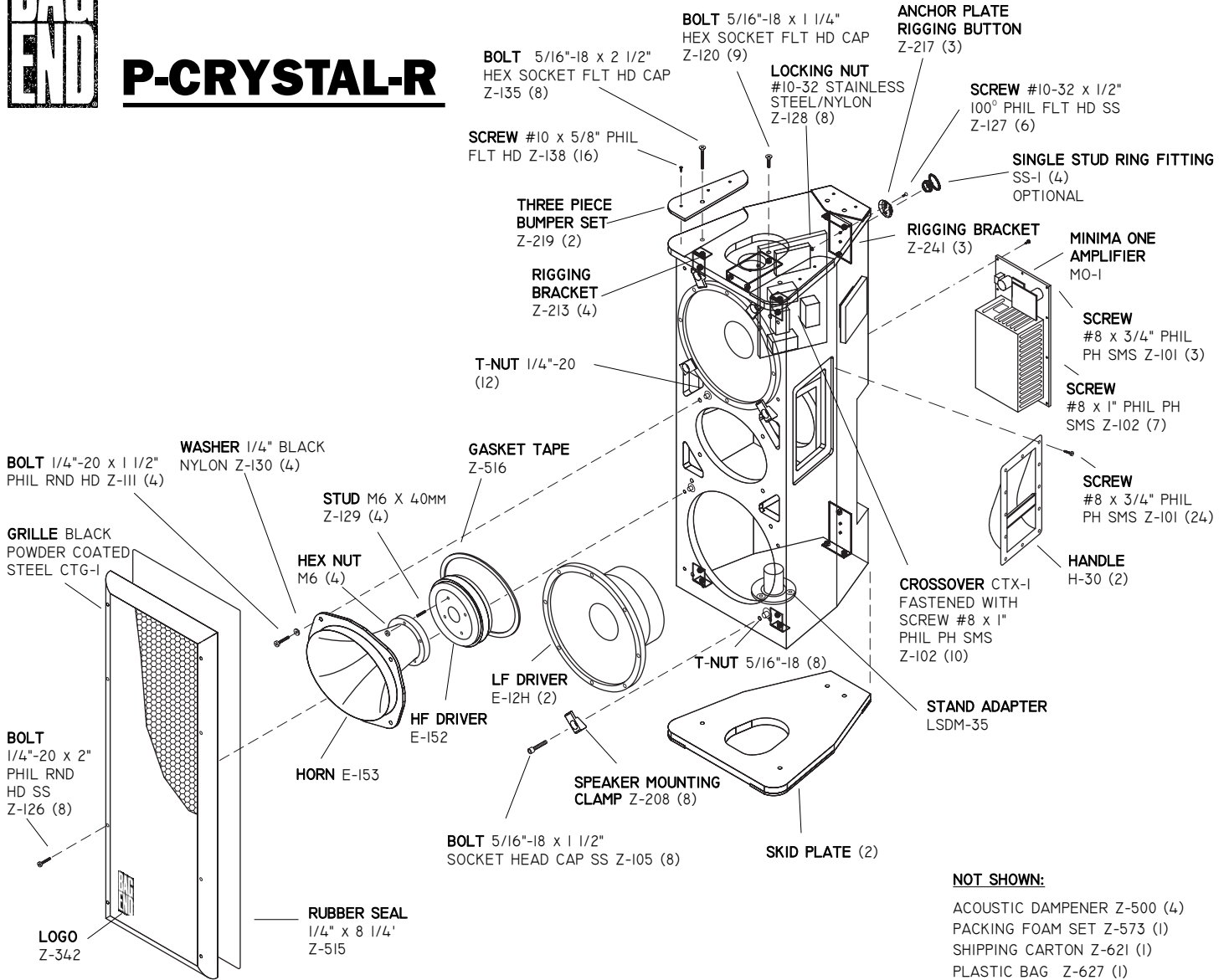

ABOUT MINIMA ONE AMPLIFIER TECHNOLOGY

The Minima One amplifier is both a hi fidelity and a high efficiency amplifier. More than 80% efficient the Minima One provides more power to the loudspeakers and creates less heat in the amplifier. In real world applications there is practically no heat emitted from the amplifier and thus requires no cooling fan. Incorporating patented technology the comparison circuit of the Minima One corrects every single cycle to drive error to zero at the end of each cycle. On average every 4 microseconds the one cycle modulator transforms and amplifies the input signal into the ideal natural pulse width modulation. Switching at 250KHz with the single cycle error correction insures extremely low distortion and high reliability.

The power factor corrected AC power input automatically and continuously adapts to any voltage between 88 and 270 volts. The Minima One is convenient to power and stable to use on any power grid in the world.

ARCHITECTURAL SPECIFICATIONS

The loudspeaker shall be a 2-way vented type system with two low frequency drivers and one high frequency compression driver with horn. Each low frequency driver shall be 300 mm (12") with a 2.7 kg (95 oz.) magnet and a rear vented back plate assembly. A 76 mm (3") copper voice coil wound on Kapton former shall be coupled to a 70F cone. The high frequency driver shall have a titanium diaphragm coupled to a 76 mm (3") copper voice coil driving a fiberglass elliptic conical horn. System dispersion of a single unit shall be 55° horizontally by 40° vertically at the -6dB points. Units shall array for wider horizontal dispersion. The frequency response shall be 80 Hz to 18 kHz ±3 dB. The system shall be Time-Aligned™ by E. M. Long Associates with a time offset at crossover of $\lt; \pm 25 \text{ microseconds}$. The system shall have an average sensitivity of 103 dB SPL with 1 Watt input at 1 meter. The system shall have a minimum power handling of 1200 Watts continuous program long term. The enclosure shall be made of 18 mm (3/4") thick 13-ply birch plywood with glued rabbet joints and internal bracing. The enclosure shall be internally dampened with 125 gram/inch² cotton acoustic treatment. The enclosure shall have two recessed handles, one per side, a 35 mm stand mounting adapter and 4 Ancra #40000 anchor plates for rigging attachments. The protective grille shall be powder coated 14 gauge perforated steel with a welded aluminum frame. The removable end caps shall be made from 18 mm (3/4") thick 13-ply birch plywood with high impact abrasion resistant UHMW polyethylene bumpers. The input connector plate shall be recessed in the back of the enclosure and shall include one dual banana connector, two 1/4" phone connectors and two Neutrik Speakon NL4MP connectors. Overall dimensions shall not exceed 101 cm (39.5") h x 37 cm (14.5") w x 44 cm (17") d. The unit shall weigh no more than 50 kg (110 pounds). The unit shall be completely painted with durable black textured paint.

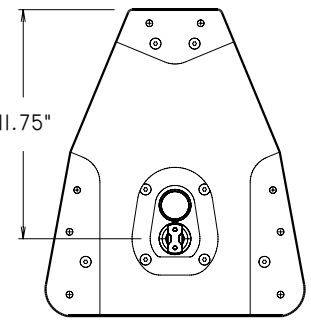
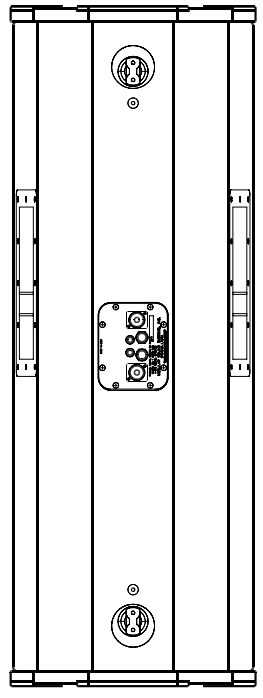
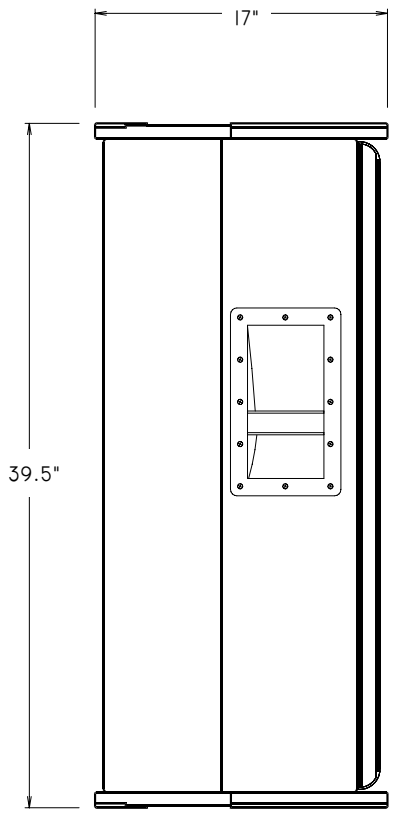
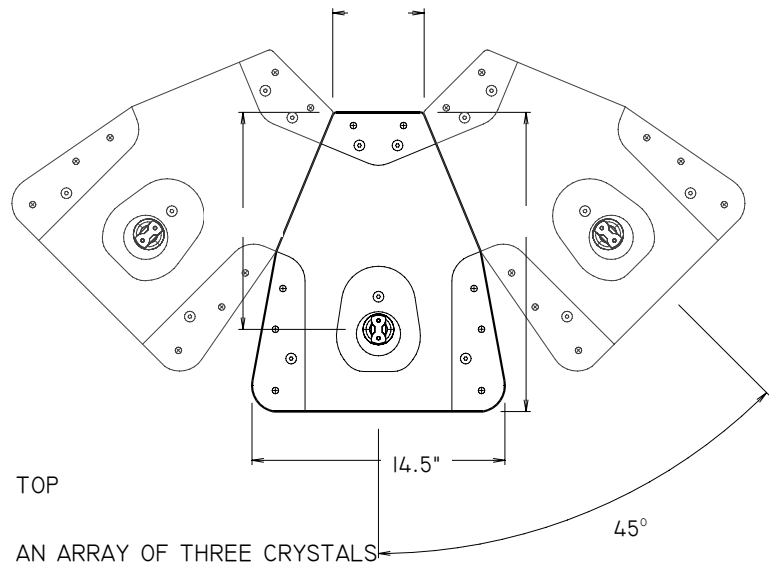

CRYSTAL POLAR RESPONSE

Instrumentation:

DSP: Techron TEF 20

Microphone: Brüel & Kjær 4007

Power amplifier: Crown Macro Reference

AC voltmeter: Hewlett Packard 400E

Software: Sound Lab TDS ver. 2.1b, Sound Lab Polar ver. 2.1c, Sound Lab SLX ver. 2.1

Polar measurements taken at 3 meters from baffle, Top of scale normalized to zero degree axis, Scale step 6 dB

Horizontal

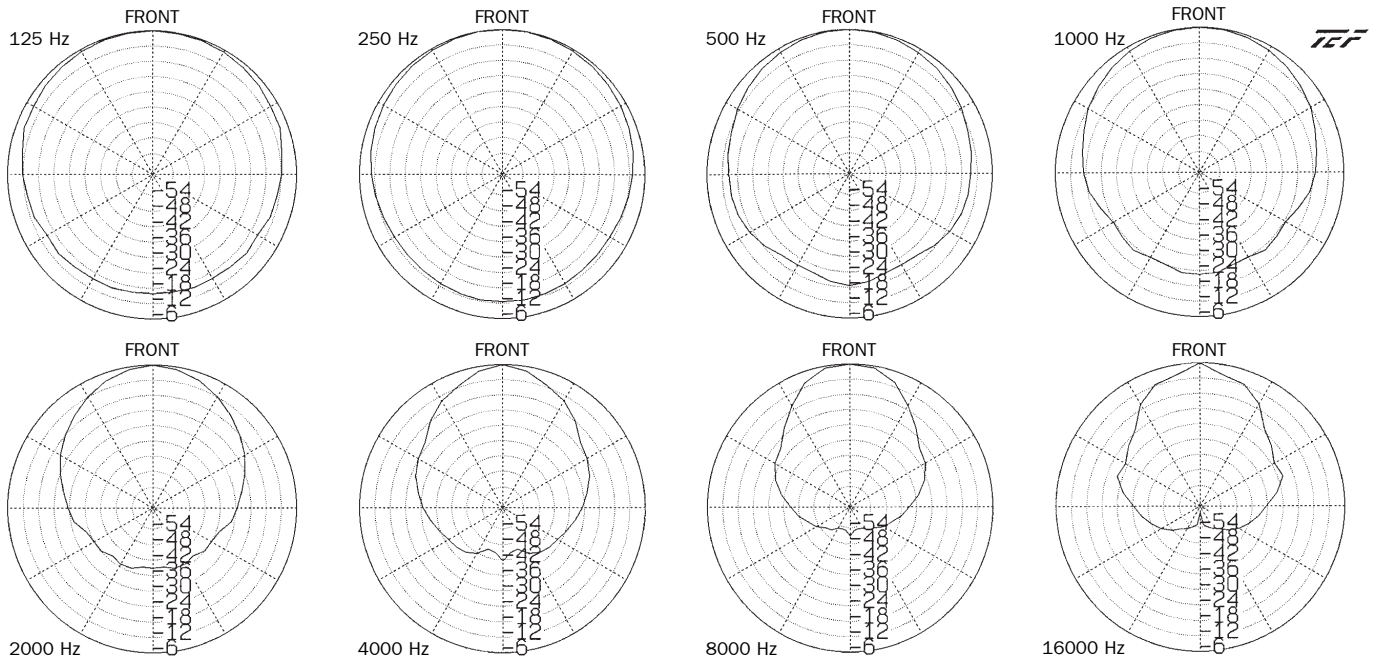

Vertical

