

## S P E C I F I C A T I O N S

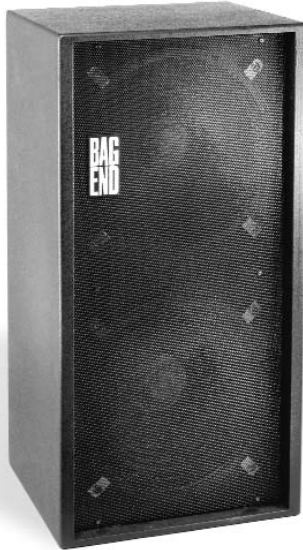

### SYSTEM COMPONENTS

**Enclosure:**

18 mm 13-ply birch plywood

**Low Frequency Transducers:**

2 - 18" INFRA cone  
3" Voice coil  
120 oz. Magnet

**Internal Amplification:**

1 - Minima One

**Grille:**

16 Gauge black vinyl coated perforated steel

**Standard Hardware:**

8 - Machined aluminum speaker mounting clamps

**Optional Hardware:**

Rigging points

### ACOUSTIC AND ELECTRICAL

**System Type:**

2 - Infrasub sealed chambers  
(3 ft<sup>3</sup> each)

**Input:**

10K  $\Omega$  Balanced XLR input with loop through

**Input CAL Sensitivity:** +4 dBu**System Power:**

1000 W continuous

**Frequency Response:**

60 Hz to 250 Hz  $\pm 3$  dB  
w/External Infra Integrator  
8 Hz to 95 Hz  $\pm 3$  dB

**Hi Pass Filter Frequency****Switchable:**

-6 dB @ 8 Hz, @ 50 Hz, @ 95 Hz

**Crossover Network:**

Requires external INFRA Integrator for 8 Hz Response

**Maximum Acoustic Output:**

Half Space @ 1 Meter  
10 Hz - 97 dB SPL  
20 Hz - 109 dB SPL  
40 Hz - 121 dB SPL  
80 Hz - 130 dB SPL

**LED Indicators:**

Green, On  
Yellow, System Limit  
Red, System Fault or Sleep Mode

**AC Power Requirements:**

88 Volts Minimum  
270 Volts Maximum

### PHYSICAL

**Standard Finish:**

Black Textured Finish

**Dimensions:**

43" h x 22" w x 18" d  
110 cm x 56 cm x 46 cm

**Weight:**

132 lbs., 60 kg

**Shipping Dimensions:**

20" x 45" x 25"  
51 cm x 115 cm x 64 cm

**Shipping Weight:**

144 lbs., 65 kg

## APPLICATIONS:

Film & Video Post Production

Recording Studio

PA System Installations

Home Theater

Discotheque

**MINIMA ONE SELF-POWERED** The P-D18E-I is a very high output self-powered subwoofer system designed to provide high fidelity extended low frequency audio reproduction from a relatively small enclosure. The P-D18E-I provides perfectly flat response down to 8 Hertz when used in conjunction with the 8 Hertz Integrator. Designed for permanent installation, the P-D18E-I offers a flat black textured finish and a black coated steel grille.

**OPTIONAL CUSTOM FINISHES** Available in white and ready-to-stain natural birch. Optional rigging points allow system to be suspended.

**ABOUT INFRA SUB TECHNOLOGY** Almost all specifications for subwoofer systems are fixated on the frequency response domain. However, the impression of power and quality is equally related to the time domain performance of a system. Because of the long wavelengths of low frequencies, this is particularly true with subwoofers. Likewise, the maximum SPL is not a very reliable way to judge the impact of a subwoofer. A poor time domain performer will not have the same impact or natural sound as a time correct INFRA system.

The reason that INFRA technology sounds dramatically better than the others is because of their superior time domain performance. The INFRA subwoofer maintains the bass energy in a tight packet, aligned with the upper range signal, providing a greater body impact and a seamless musical connection with the main loudspeakers.

Conventional subwoofers designs perform so poorly in the time domain because designers have used methods that sacrifice the phase response for more control over the frequency response (e.g., steep low pass filter slopes, vented speaker enclosures, and narrow bandwidth systems). With the INFRA technique, we do not degrade the phase response while extending the frequency response.

While the INFRA dual integrator does function as the system crossover, it does so without using a low pass filter. Adding a low pass filter, analog or digital, will have a degrading effect on the time domain performance of the INFRA subwoofer. A low pass filter adds signal delay to the sound which varies with frequency. Also, narrowing the pass band increases the influence of the rolloff on both ends of the subwoofer spectrum. The result is the smearing of the arrival times of the low frequency sound components, changing the timbre and downgrading the impact of transient sounds.

The Bag End INFRA subwoofers are designed as no-compromise, high fidelity reproduction systems. We believe they are the finest subs available, regardless of price.

**BAG END Loudspeakers**  
22N272 Pepper Road  
Lake Barrington, Illinois  
60010 USA  
Voice 847 382 4550  
Fax 847 382 4551  
www.bagend.com





# P-D18E-I

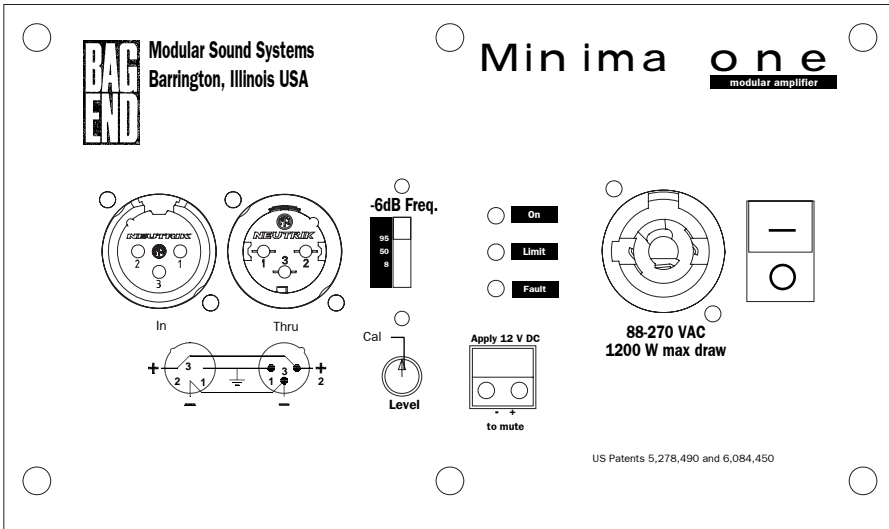
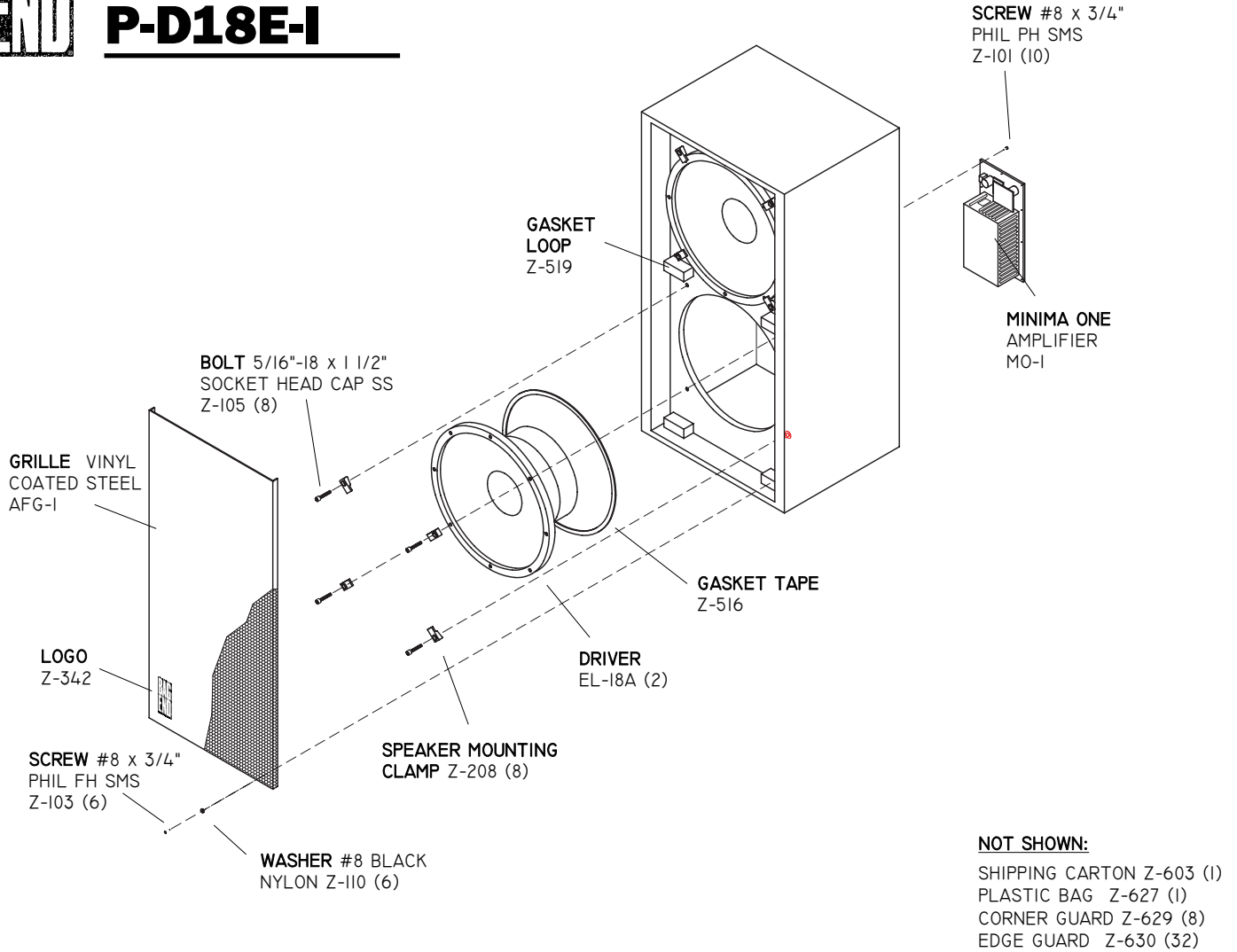

## ABOUT MINIMA ONE AMPLIFIER

**TECHNOLOGY** The Minima One amplifier is both a hi fidelity and a high efficiency amplifier. More than 80% efficient the Minima One provides more power to the loudspeakers and creates less heat in the amplifier. In real world applications there is practically no heat emitted from the amplifier and thus requires no cooling fan. Incorporating patented technology the comparison circuit of the Minima One corrects every single cycle to drive error to zero at the end of each cycle. On average every 4 microseconds the one cycle modulator transforms and amplifies the input signal into the ideal natural pulse width modulation. Switching at 250KHz with the single cycle error correction insures extremely low distortion and high reliability.

The power factor corrected AC power input automatically and continuously adapts to any voltage between 88 and 270 volts. The Minima One is convenient to power and stable to use on any power grid in the world.