

BAG END SELF-POWERED

INSTALLATION SERIES

PTA2000-I TIME-ALIGN®

S P E C I F I C A T I O N S



SYSTEM COMPONENTS

Enclosure:

18 mm 13-ply birch plywood

Low Frequency Transducer:

12" Cone
2.5" Voice coil
80 oz. Magnet

High Frequency Transducer:

1" Exit compression driver
1.8" Titanium diaphragm
15 oz. Magnet
Radial Horn

Internal Amplification:

1 - Minima One

Grille:

16 Gauge black vinyl
coated perforated steel

Hardware:

Rigging points

ACOUSTIC AND ELECTRICAL

System Type:

2-way vented 2 ft³

Input: 48k Ω Balanced XLR
inputs with loop through

Input CAL Sensitivity: +4 dBu

System Power:

500 W continuous w/system limiter

Frequency Response:

70 Hz to 20 kHz ± 3 dB
(4 π Steradians)

Hi Pass Filter Frequency

Switchable:

-6dB @ 8 Hz, @ 50 Hz, @ 95 Hz

Dispersion:

80° Horizontal (-6 dB)
60° Vertical (-6 dB)
(Horn may be rotated 90° for a
60° H x 80° V dispersion)

Crossover Network:

Passive Time-Align® equalizer
type at 2.5 kHz

Time Offset Between Drivers:

< ± 25 Microseconds

Maximum Acoustic Output:

Half Space @ 1 Meter
127 dB SPL

LED Indicators:

Green, On
Yellow, System Limit
Red, System Fault or Sleep Mode

AC Power Requirements:

88 Volts Minimum
270 Volts Maximum

PHYSICAL

Standard Finish:

Black textured finish

Dimensions:

21" h x 17" w x 18" d
54 cm x 44 cm x 46 cm
Trapezoidal, 11° taper per side

Weight:

55 lbs., 25 kg

Shipping Dimensions:

23" x 25" x 21"
59 cm x 64 cm x 54 cm

Shipping Weight:

66 lbs., 30 kg

APPLICATIONS:

Auditorium Sound Reinforcement

Church Sound Reinforcement

Film and Video Post Production

Nightclub Installations

MINIMA ONE SELF POWERED The PTA2000-I is a permanent installation full range self-powered loudspeaker system offering both high fidelity and high efficiency. The Time-Aligned™ studio quality sound provides detail and clarity not found in other designs. Rugged birch plywood enclosure finished with our beautiful utility black textured finish and a black steel grille will fit nicely into almost any application. Standard flying attachment points allow for safe and convenient rigging.

OPTIONAL CUSTOM FINISHES Available in textured white paint or ready-to-stain natural birch for greater versatility in location and aesthetics. Also available in outdoor weather resistant package.

ABOUT TIME-ALIGN® Time-Align® assures that the fundamental and overtones of a complex, transient, acoustical signal are presented to the listener in the same relationship as the electrical signal at the input terminals of the loudspeaker.

The conventional loudspeaker spreads out the sound in time: when a rapid series of transients occur the results are blurring and lost detail. With Time-Align®, a transient is presented as a tight package of energy, with the same time relationships as the natural sound. This means that a rapid series of transients will be heard clearly.

True Time-Alignment™ requires much more than just physically lining up the loudspeaker components. It requires consideration of the driver placement, driver delay and adjustment of the crossover delay parameters. This achieves the precise simultaneous acoustical arrival time of each driver throughout the crossover region.

Along with state-of-the-art laboratory instruments, the proprietary Time-Align® generator, built by Ron Wickersham, is used in designing our loudspeaker systems. The Time-Align® generator is founded upon different underlying principles than are used in the more common Fourier based measurement equipment.

When comparing a genuine BAG END Time-Aligned™ speaker system to any other, our additional design work is easy to hear and appreciate. The dramatic clarity, realism, and overall pleasant sound of our Time-Aligned™ loudspeakers is noted throughout the world.

BAG END Loudspeakers
22N272 Pepper Road
Lake Barrington, Illinois
60010 USA
Voice 847 382 4550
Fax 847 382 4551
www.bagend.com





PTA2000-I

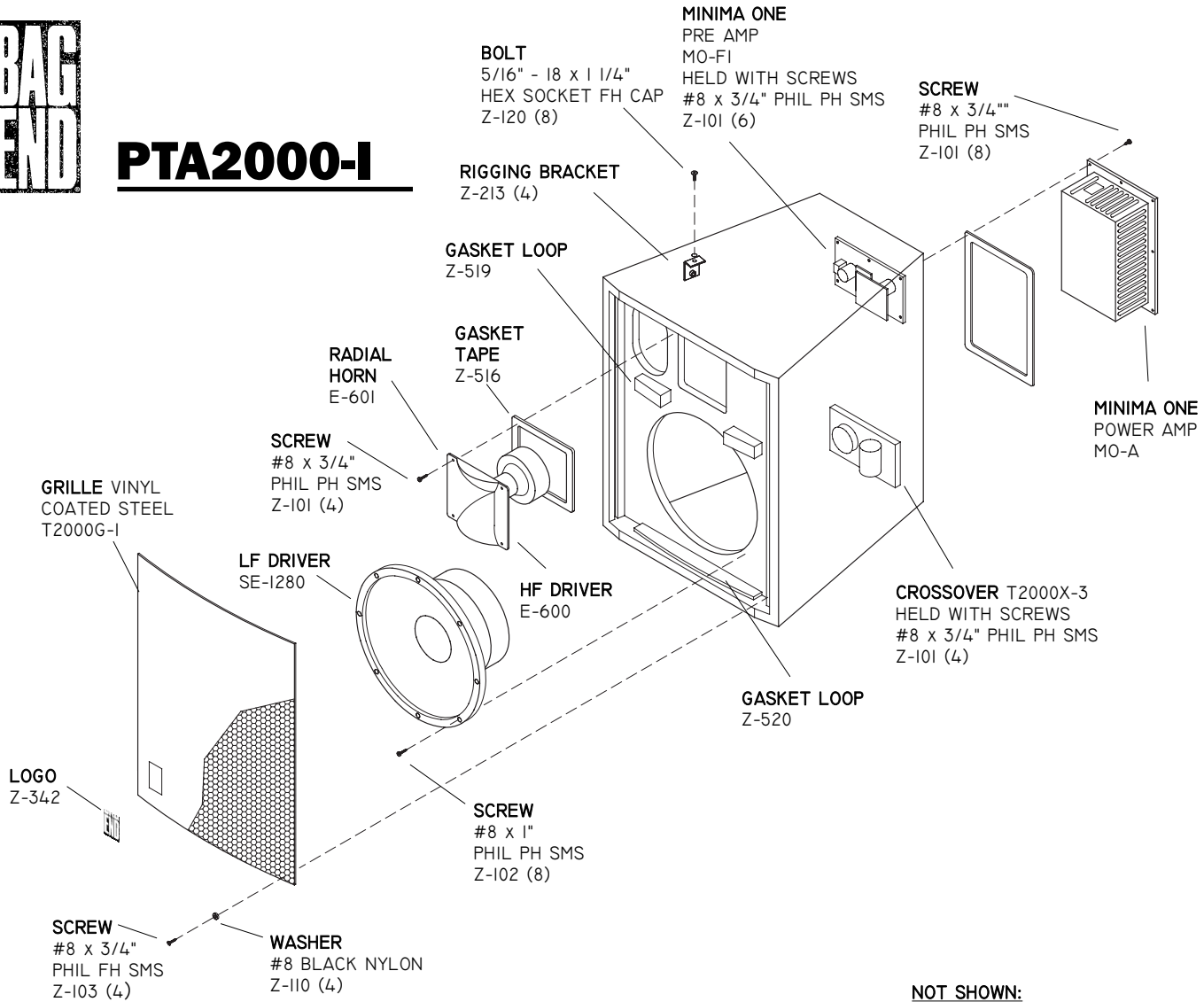

NOT SHOWN:

- ACOUSTIC DAMPENER Z-500 (4.2)
- SHIPPING CARTON Z-612 (1)
- PLASTIC BAG Z-627 (1)
- CORNER GUARD Z-629 (8)
- EDGE GUARD Z-630 (16)

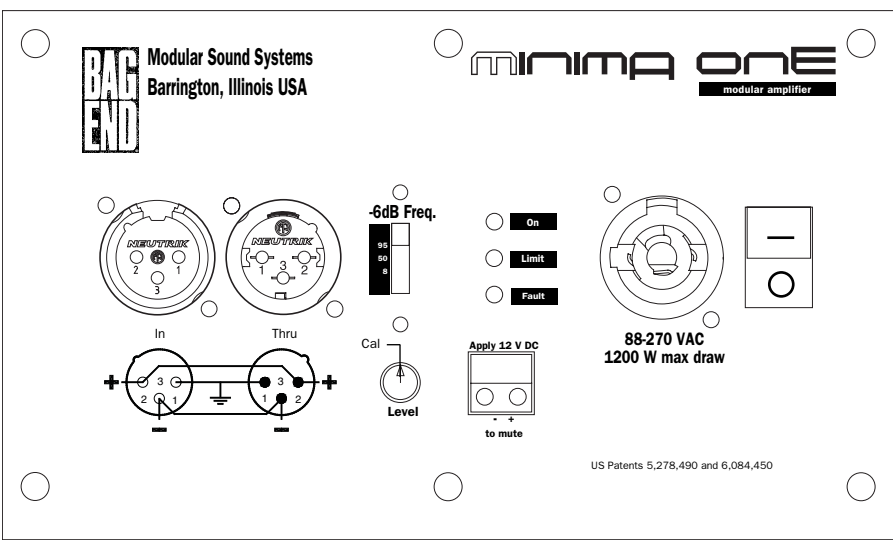

ABOUT MINIMA ONE AMPLIFIER TECHNOLOGY

The Minima One amplifier is both a hi fidelity and a high efficiency amplifier. More than 80% efficient the Minima One provides more power to the loudspeakers and creates less heat in the amplifier. In real world applications there is practically no heat emitted from the amplifier and thus requires no cooling fan. Incorporating patented technology the comparison circuit of the Minima One corrects every single cycle to drive error to zero at the end of each cycle. On average every 4 microseconds the one cycle modulator transforms and amplifies the input signal into the ideal natural pulse width modulation. Switching at 250KHz with the single cycle error correction insures extremely low distortion and high reliability.

The power factor corrected AC power input automatically and continuously adapts to any voltage between 88 and 270 volts. The Minima One is convenient to power and stable to use on any power grid in the world.