



### SYSTEM COMPONENTS

#### Enclosure:

18 mm 13-ply birch plywood  
Floor monitor angle: 45°  
Compound angle arrayability

#### Low Frequency Transducer:

12" Cone  
3" Voice coil  
95 oz. Magnet

#### High Frequency Transducer:

1.4" Exit compression driver  
3" Titanium diaphragm  
Elliptic conical horn

#### Input Connectors:

1 - Dual banana  
2 - 1/4" Phone  
2 - Neutrik Speakon

#### Grille:

14 Gauge black powder coated perforated steel in an extruded aluminum frame with weather seal

#### Standard Hardware:

Rigging points  
1 - 35 mm Stand adapter  
2 - Recessed handles  
4 - Machined aluminum speaker mounting clamps

### ACOUSTIC AND ELECTRICAL

#### System Type:

2-way vented 1.7 ft<sup>3</sup>

#### Impedance:

8 Ω

#### Crossover Network:

Passive Time-Align® equalizer type @ 1.9 kHz

#### Time Offset Between Drivers:

< ± 25 Microseconds

#### Frequency Response:

95 Hz to 18 kHz ±3 dB  
(4π Steradians)

#### Sensitivity:

100 dB SPL (1W @ 1m)

#### Dispersion:

55° Horizontal (-6 dB)  
40° Vertical (-6 dB)

#### Power Handling:

300 W continuous sine wave  
600 W continuous program  
1200 W instantaneous peak

### PHYSICAL

#### Finish:

Black textured catalyzed urethane

#### Dimensions:

24" h x 14" w x 17.5" d  
61 cm x 36 cm x 45 cm

#### Weight:

68 lbs.  
31 kg

#### Shipping Dimensions:

21" x 30" x 25"  
54 cm x 77 cm x 64 cm

#### Shipping Weight:

81 lbs.  
37 kg

## APPLICATIONS:

**Stadium Sound Reinforcement**  
**Auditorium Sound Reinforcement**  
**Church Sound Reinforcement**  
**Audio Visual Presentations**  
**Nightclub Applications**  
**Portable Sound Reinforcement**  
**Live Stage Monitoring**

**SAPPHIRE-R** The SAPHIRE is a full range, compact, multi-functioning loudspeaker system offering high fidelity, high efficiency and high power handling capacity. The SAPHIRE's unique enclosure allows for floor monitoring, stand mounting and flying applications. Designed for compact arrays where the cluster is flown above the audience, the SAPHIRE allows compound angle arraying of the enclosures. For a complete 360° circular array, seven SAPHIRES may be placed together. The SAPHIRE-R includes handles, a stand adapter, quick-release rigging attachment points and is ATM Flyware™ compatible. Constructed from 18 mm 13-ply birch plywood and finished in black catalyzed urethane, the SAPHIRE-R enclosure is durable and attractive. In addition, weatherproofing options are available.

**About Time-Align®** Time-Align® assures that the fundamental and overtones of a complex, transient, acoustical signal are presented to the listener in the same relationship as the electrical signal at the input terminals of the loudspeaker.

The conventional loudspeaker spreads out the sound in time: when a rapid series of transients occur the results are blurring and lost detail. With Time-Align®, a transient is presented as a tight package of energy, with the same time relationships as the natural sound. This means that a rapid series of transients will be heard clearly.

True Time-Alignment™ requires much more than just physically lining up the loudspeaker components. It requires consideration of the driver placement, driver delay and adjustment of the crossover delay parameters. This achieves the precise simultaneous acoustical arrival time of each driver throughout the crossover region.

Along with state-of-the-art laboratory instruments, the proprietary Time-Align® generator, built by Ron Wickersham, is used in designing our loudspeaker systems. The Time-Align® generator is founded upon different underlying mathematical principles than are used in the more common Fourier based measurement equipment.

When comparing a genuine BAG END Time-Aligned™ speaker system to any other, our additional design work is easy to hear and appreciate. The dramatic clarity, realism, and overall pleasant sound of our Time-Aligned™ loudspeakers is noted throughout the world.

**BAG END Loudspeakers**  
22272 Pepper Road  
Barrington, Illinois  
60010 USA  
Voice 847 382 4550  
Fax 847 382 4551  
www.bagend.com





# SAPPHIRE-R

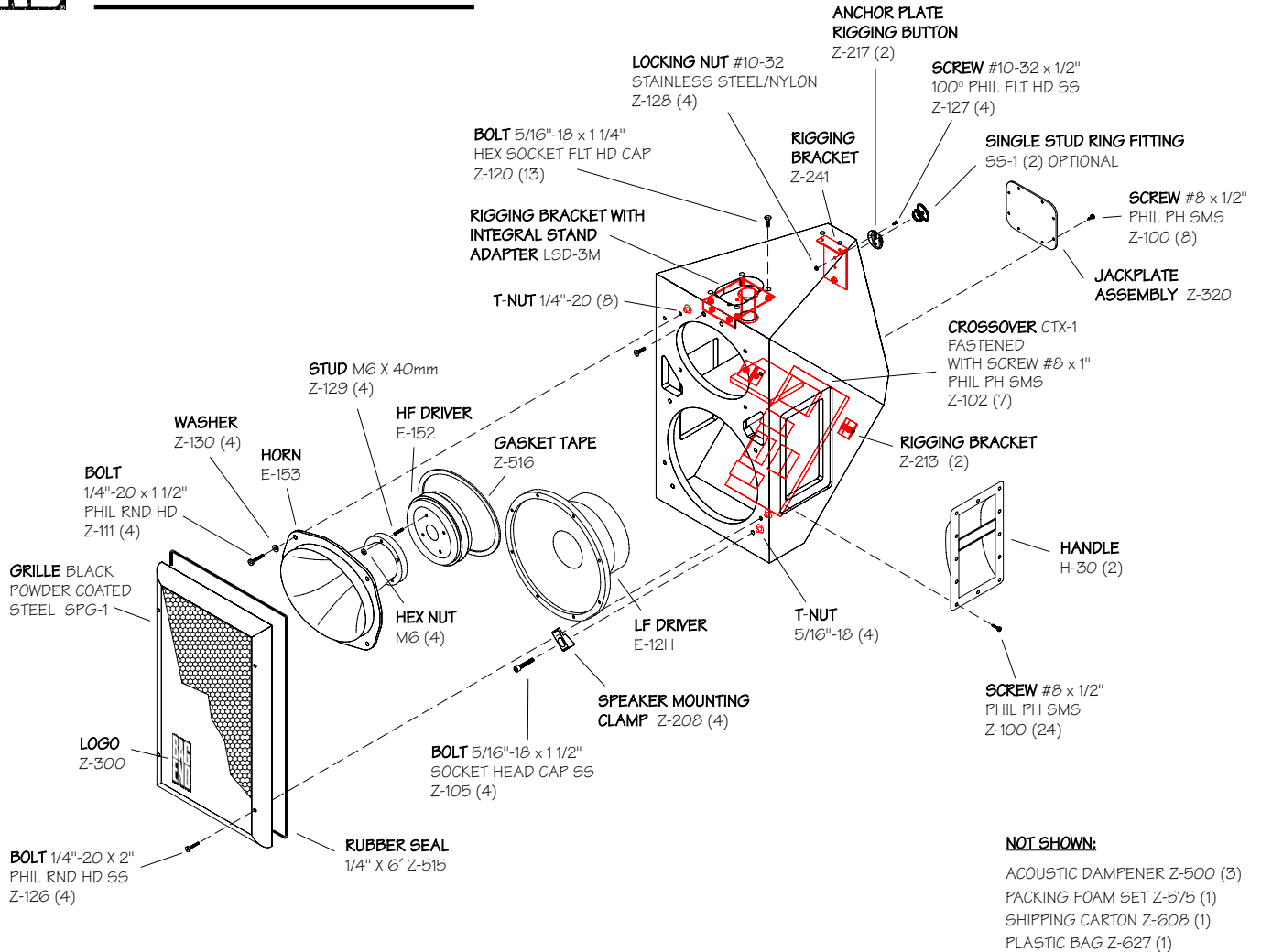

## SYSTEM SCHEMATIC

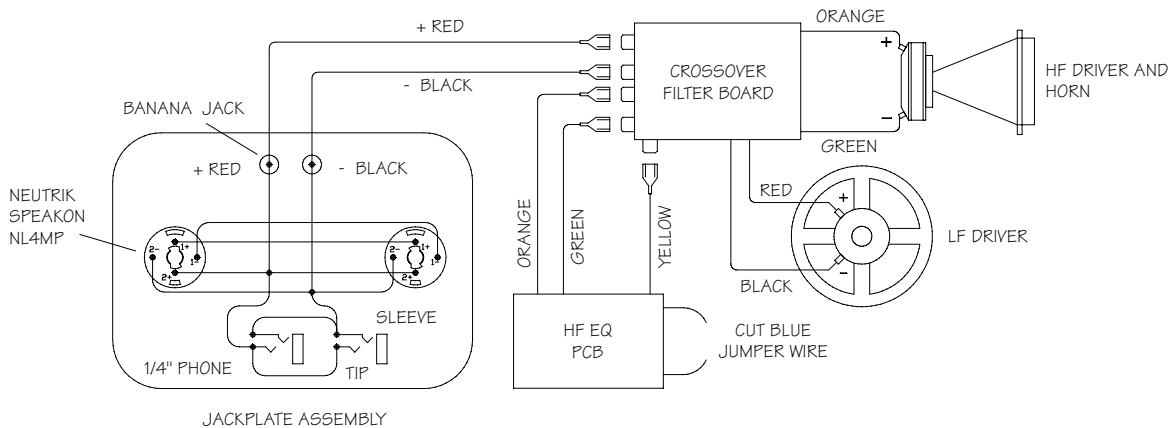

The Neutrik Speakon NL4MP connector is a keyed, high current, four conductor device which allows both the high and low frequency signals for a bi-amped loudspeaker system to run through the same 4-conductor cable. Note that all four conductors on both connectors are wired in parallel, but only two conductors are connected to the drivers in the enclosure. This permits an easy parallel connection to other similar loudspeakers (if your amplifier can handle the low impedance load!) and allows the use of a short "jumper" between the subwoofers and the mid/high speakers in a bi-amped system. Banana and 1/4" phone jacks are also provided.

# ARCHITECTURAL SPECIFICATIONS

The loudspeaker shall be a 2-way vented type system with one low frequency driver and one high frequency compression driver with horn. The low frequency driver shall be 300 mm (12") with a 2.7 kg (95 oz.) magnet and a rear vented back plate assembly. A 76 mm (3") copper voice coil wound on Kapton former shall be coupled to a 70F cone. The high frequency driver shall have a titanium diaphragm coupled to a 76 mm (3") copper voice coil driving a fiberglass elliptical conical horn. System dispersion of a single unit shall be 55° horizontally by 40° vertically at the -6dB points. Units shall array for wider horizontal dispersion. The frequency response shall be 95 Hz to 18 kHz  $\pm$ 3 dB. The system shall be Time-Aligned™ by E. M. Long Associates with a time offset at crossover of  $<\pm$ 25 microseconds. The system shall have an average sensitivity of 100 dB SPL with 1 Watt input at 1 meter. The system shall have a minimum power handling of 600 Watts continuous program long term. The enclosure shall be made of 18 mm (3/4") thick 13-ply birch plywood with glued rabbet joints and internal bracing. The enclosure shall be internally dampedened with 125 gram/inch<sup>2</sup> cotton acoustic treatment. The enclosure shall have two recessed handles, one per side, a 35 mm stand mounting adapter and 2 Ancra #40000 anchor plates for rigging attachments. The protective grille shall be powder coated 14 gauge perforated steel with a welded aluminum frame. The input connector plate shall be recessed in the back of the enclosure and shall include one dual banana connector, two 1/4" phone connectors and two Neutrik Speakon NL4MP connectors. Overall dimensions shall not exceed 61 cm (24") h x 36 cm (14") w x 45 cm (17.5") d. The unit shall weigh no more than 31 kg (68 pounds). The unit shall be completely painted with durable black textured catalyzed urethane.

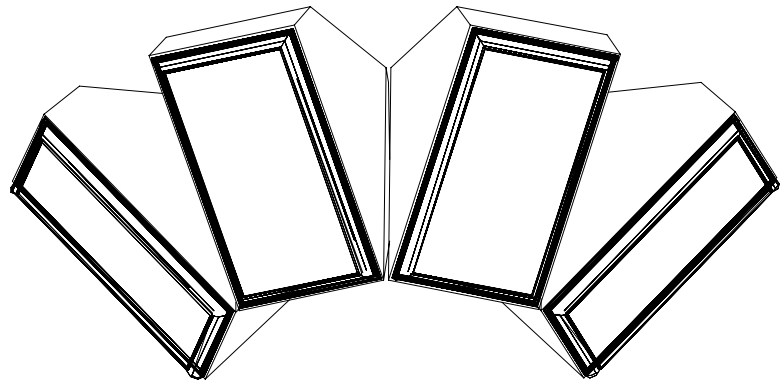

AN ARRAY OF FOUR SAPPHIRES

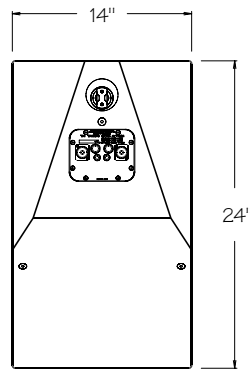
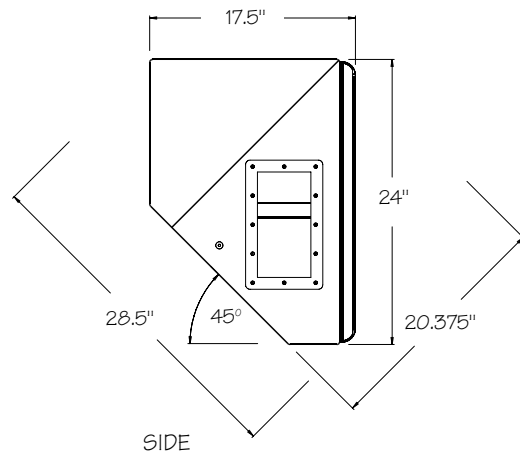

BOTTOM

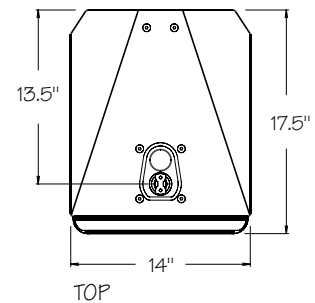

TOP

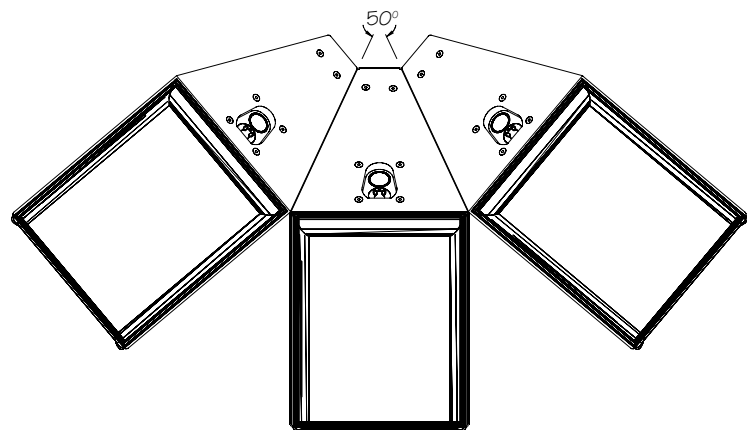

PLAN VIEW

# SAPPHIRE POLAR RESPONSE

## Instrumentation:

**DSP:** Techron TEF 20

**Microphone:** Brüel & Kjær 4007

**Power amplifier:** Crown Macro Reference

**AC voltmeter:** Hewlett Packard 400E

**Software:** Sound Lab TDS ver. 2.1b, Sound Lab Polar ver. 2.1c, Sound Lab SLX ver. 2.1

Polar measurements taken at 3 meters from baffle, Top of scale normalized to zero degree axis, Scale step 6 dB

## Horizontal

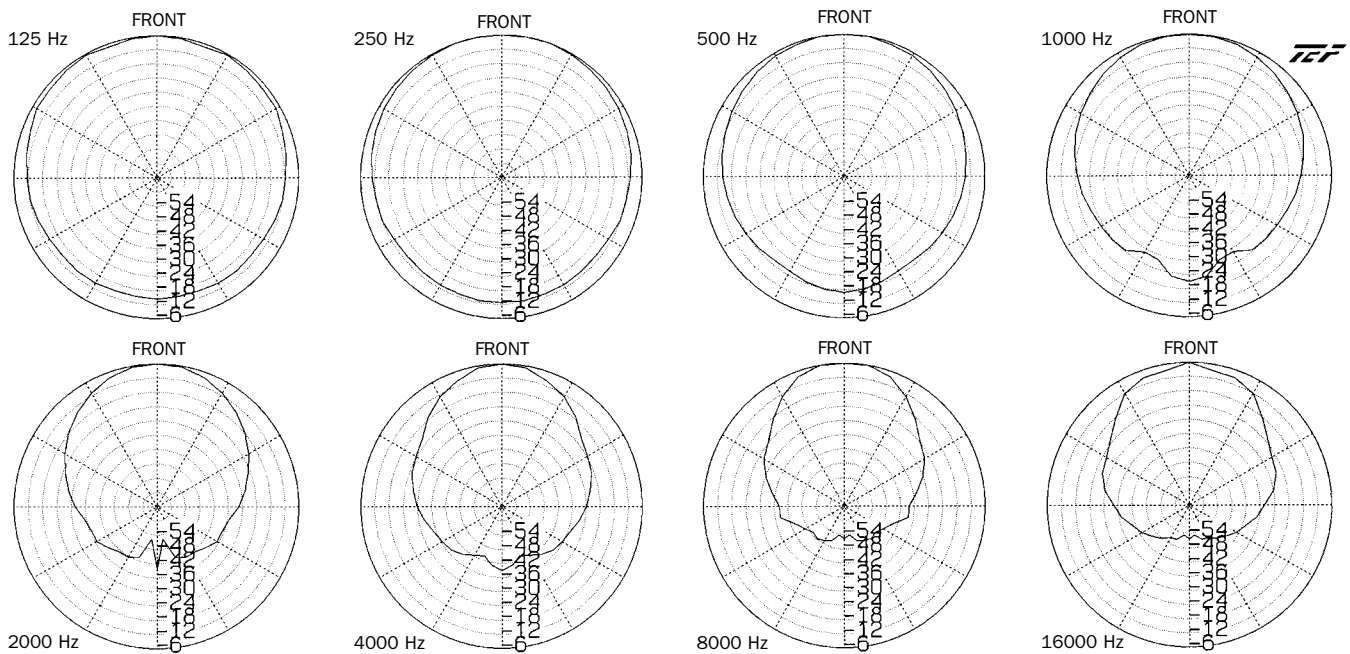

## Vertical

