

**SYSTEM COMPONENTS****Enclosure:**

18 mm 13-ply birch plywood

Low Frequency Transducer:

15" Cone
2.5" Voice coil
80 oz. Magnet

High Frequency Transducer:

1" Exit compression driver
1.25" Titanium diaphragm
24 oz. Magnet
Exponential horn

Input Connectors:

Cinch 142 screw terminal
barrier strip

Grille:

16 Gauge black vinyl
coated perforated steel

Hardware:

F6 Rigging points

ACOUSTIC AND ELECTRICAL**System type:**

2-way vented 3.4 ft³

Impedance:

8 Ω

Crossover Network:

Passive Time-Align® equalizer
type at 1.7 kHz

Time Offset Between Drivers:

< ± 25 Microseconds

Frequency Response:

50 Hz to 19 kHz ±3 dB
(4π Steradians)

Sensitivity:

101 dB SPL (1W @ 1m)

Dispersion:

90° Horizontal (-6 dB)
40° Vertical (-6 dB)

Power Handling:

200 W continuous sine wave
800 W instantaneous peak

PHYSICAL**Finish:**

Black textured finish

Dimensions:

27" h x 22" w x 18" d
69 cm x 56 cm x 46 cm
Trapezoidal, 8° taper per side

Weight:

75 lbs.
34 kg

Shipping Dimensions:

21" x 30" x 25"
54 cm x 76 cm x 64 cm

Shipping Weight:

83 lbs.
38 kg

APPLICATIONS:

Auditorium Sound Reinforcement

Church Sound Reinforcement

Nightclub Applications

DJ System Installation

TA5000-I The TA5000-I is a permanent installation full range loudspeaker system offering both high fidelity and high efficiency. The Time-Aligned™ studio quality sound provides detail and clarity not found in other designs. Rugged birch plywood with our beautiful utility black textured finish and a black steel grille will fit nicely into almost any application. Optional flying attachment points allow for safe and convenient rigging.

About Time-Align® Time-Align® assures that the fundamental and overtones of a complex, transient, acoustical signal are presented to the listener in the same relationship as the electrical signal at the input terminals of the loudspeaker.

The conventional loudspeaker spreads out the sound in time: when a rapid series of transients occur the results are blurring and lost detail. With Time-Align®, a transient is presented as a tight package of energy, with the same time relationships as the natural sound. This means that a rapid series of transients will be heard clearly.

True Time-Alignment™ requires much more than just physically lining up the loudspeaker components. It requires consideration of the driver placement, driver delay and adjustment of the crossover delay parameters. This achieves the precise simultaneous acoustical arrival time of each driver throughout the crossover region.

Along with state-of-the-art laboratory instruments, the proprietary Time-Align® generator, built by Ron Wickersham, is used in designing our loudspeaker systems. The Time-Align® generator is founded upon different underlying mathematical principles than are used in the more common Fourier based measurement equipment.

When comparing a genuine BAG END Time-Aligned™ speaker system to any other, our additional design work is easy to hear and appreciate. The dramatic clarity, realism, and overall pleasant sound of our Time-Aligned™ loudspeakers is noted throughout the world.

BAG END Loudspeakers
22N272 Pepper Road
Lake Barrington, Illinois
60010 USA
Voice 847 382 4550
Fax 847 382 4551
www.bagend.com





TA5000-I

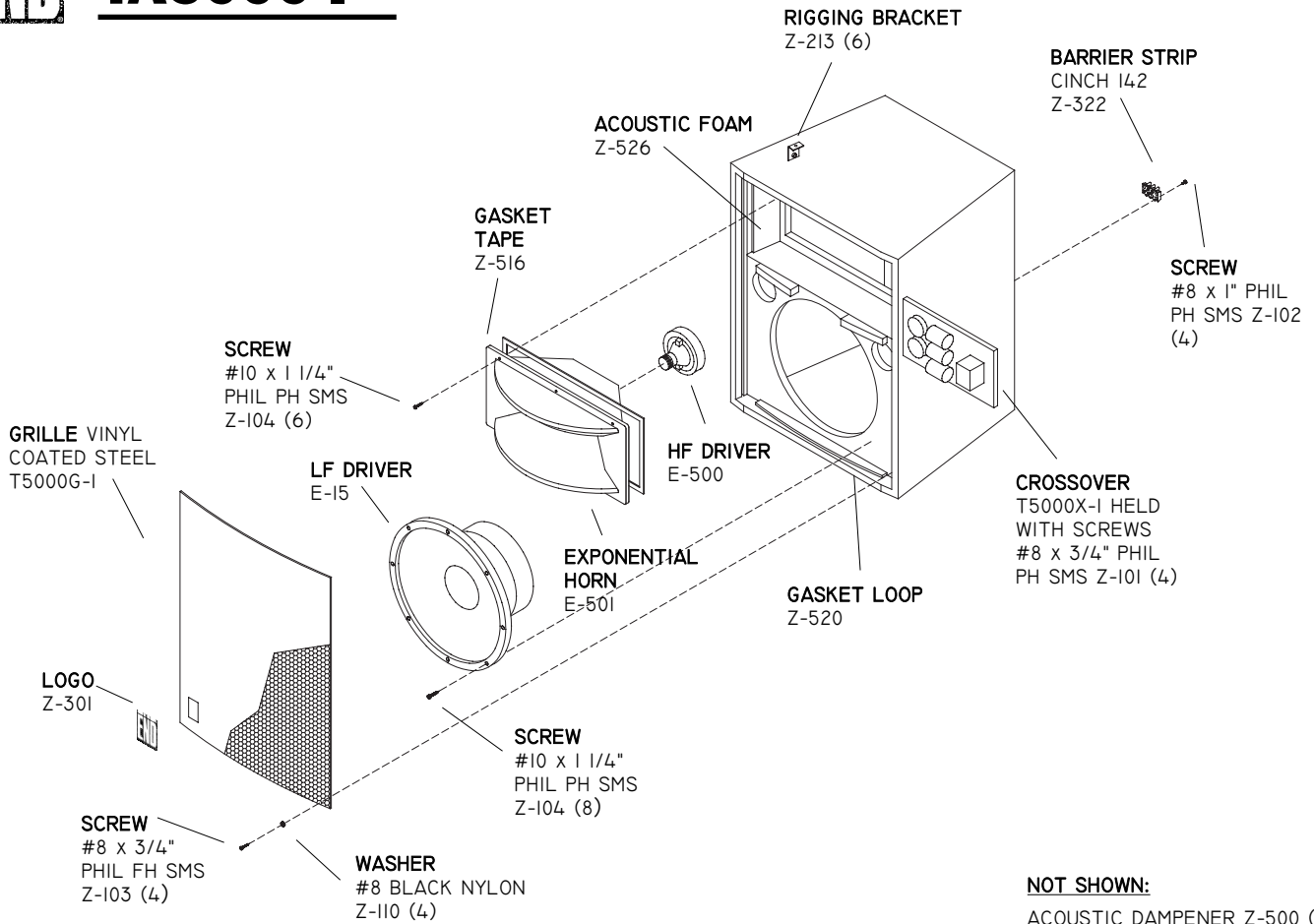

NOT SHOWN:
 ACOUSTIC DAMPENER Z-500 (7.5)
 SHIPPING CARTON Z-608 (1)
 PLASTIC BAG Z-627 (1)
 CORNER GUARD Z-629 (4)
 EDGE GUARD Z-630 (14)

SYSTEM SCHEMATIC

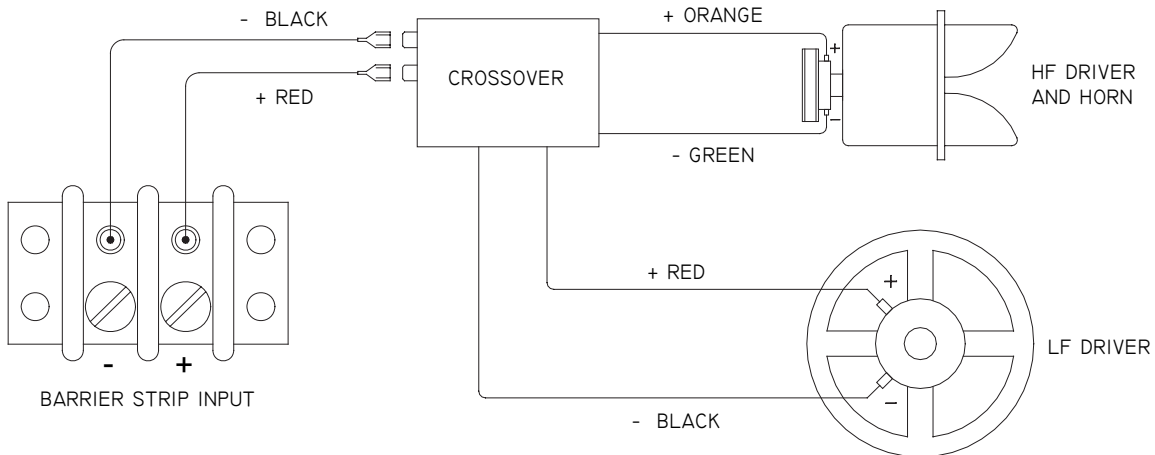

BAG END

TA5000-I TIME-ALIGN®

F6 rigging points

⊕ = Center of Gravity

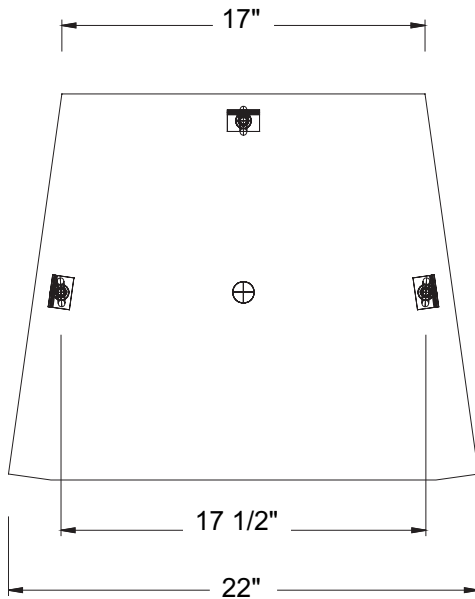
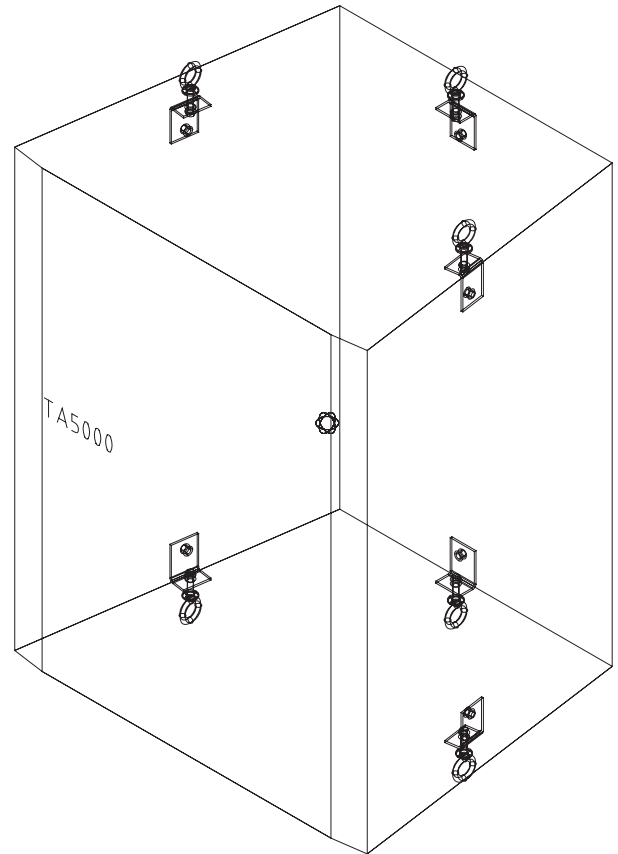
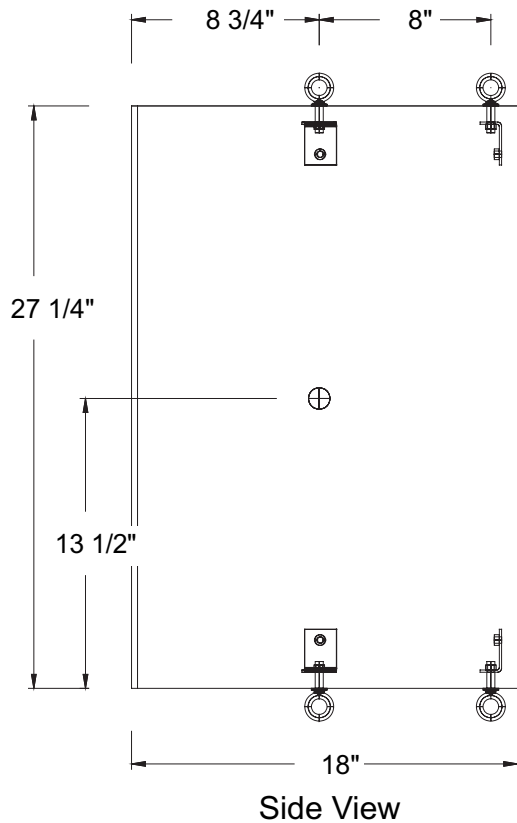

Warning:

Mounting and rigging loudspeakers requires experienced professionals. Improperly installed loudspeakers can result in property damage, personal injury, death and/or liability to the installing contractor.

F6 flypoints are as shown, and include (3) 5/16"-18 forged shoulder eyebolts.

BAG END Loudspeakers
22N272 Pepper Road
Lake Barrington, Illinois
60010 USA
Voice 847 382 4550
Fax 847 382 4551
www.bagend.com

