



SYSTEM COMPONENTS

Enclosure:

15 mm 11-ply birch plywood

Low Frequency Transducers:

2 - 6.5" Cone
1.5" Voice coil
30 oz. Magnet

High Frequency Transducer:

1" Exit compression driver
1.8" Titanium diaphragm
15 oz. Magnet
Bi-radial horn

Input Connectors:

Cinch 142 screw terminal
barrier strip

Grille:

16 Gauge black powder
coated perforated steel

Standard Hardware:

Rigging points

Optional Hardware:

Forged steel eyebolts
Wall mount bracket
Steel yoke kit
TA jackplate

ACOUSTIC AND ELECTRICAL

System Type:

2-way vented 0.6 ft³

Impedance:

8 Ω

Crossover Network:

Passive Time-Align® equalizer
type at 2.1 kHz

Time Offset Between Drivers:

< ± 25 Microseconds

Frequency Response:

95 Hz to 20 kHz ±3 dB
(4π Steradians)

Sensitivity:

95 dB SPL (1W @ 1m)

Dispersion:

80° Horizontal (-6 dB)
60° Vertical (-6 dB)
(Horn may be rotated 90° for
a 60° H x 80° V dispersion)

Power Handling:

150 W continuous sine wave
600 W instantaneous peak

PHYSICAL

Finish:

Black textured paint

Dimensions:

22.5" h x 9" w x 11" d
58 cm x 23 cm x 28 cm
Trapezoidal, 10° taper per side

Weight:

27 lbs.
13 kg

Shipping Dimensions:

28" x 16" x 16"
72 cm x 41 cm x 41 cm

Shipping Weight:

34 lbs.
16 kg

APPLICATIONS:

Audio Visual Presentations

Home Theater

Foreground Music Systems

Church Sound Reinforcement

Under Balcony Reinforcement

TA6002-I The TA6002-I is a compact speech range loudspeaker system offering both high fidelity and high efficiency. The Time-Aligned™ studio quality sound provides detail and clarity not found in other designs. For high power applications, the addition of an INFRA™ subwoofer extends the capabilities to full range sound reinforcement. The TA6002-I is made from durable birch plywood coated with black textured paint. Included are rigging attachment points and a rugged steel grille. Attachment points are also provided for Bag End mounting bracket (BRKT-1), Bag End yoke (YOKE-6K), and other popular mounting hardware.

About Time-Align® Time-Align® assures that the fundamental and overtones of a complex, transient, acoustical signal are presented to the listener in the same relationship as the electrical signal at the input terminals of the loudspeaker.

The conventional loudspeaker spreads out the sound in time: when a rapid series of transients occur the results are blurring and lost detail. With Time-Align®, a transient is presented as a tight package of energy, with the same time relationships as the natural sound. This means that a rapid series of transients will be heard clearly.

True Time-Alignment™ requires much more than just physically lining up the loudspeaker components. It requires consideration of the driver placement, driver delay and adjustment of the crossover delay parameters. This achieves the precise simultaneous acoustical arrival time of each driver throughout the crossover region.

Along with state-of-the-art laboratory instruments, the proprietary Time-Align® generator, built by Ron Wickersham, is used in designing our loudspeaker systems. The Time-Align® generator is founded upon different underlying mathematical principles than are used in the more common Fourier based measurement equipment.

When comparing a genuine BAG END Time-Aligned™ speaker system to any other, our additional design work is easy to hear and appreciate. The dramatic clarity, realism, and overall pleasant sound of our Time-Aligned™ loudspeakers is noted throughout the world.

BAG END Loudspeakers
22N272 Pepper Road
Lake Barrington, Illinois
60010 USA
Voice 847 382 4550
Fax 847 382 4551
www.bagend.com





TA6002-I

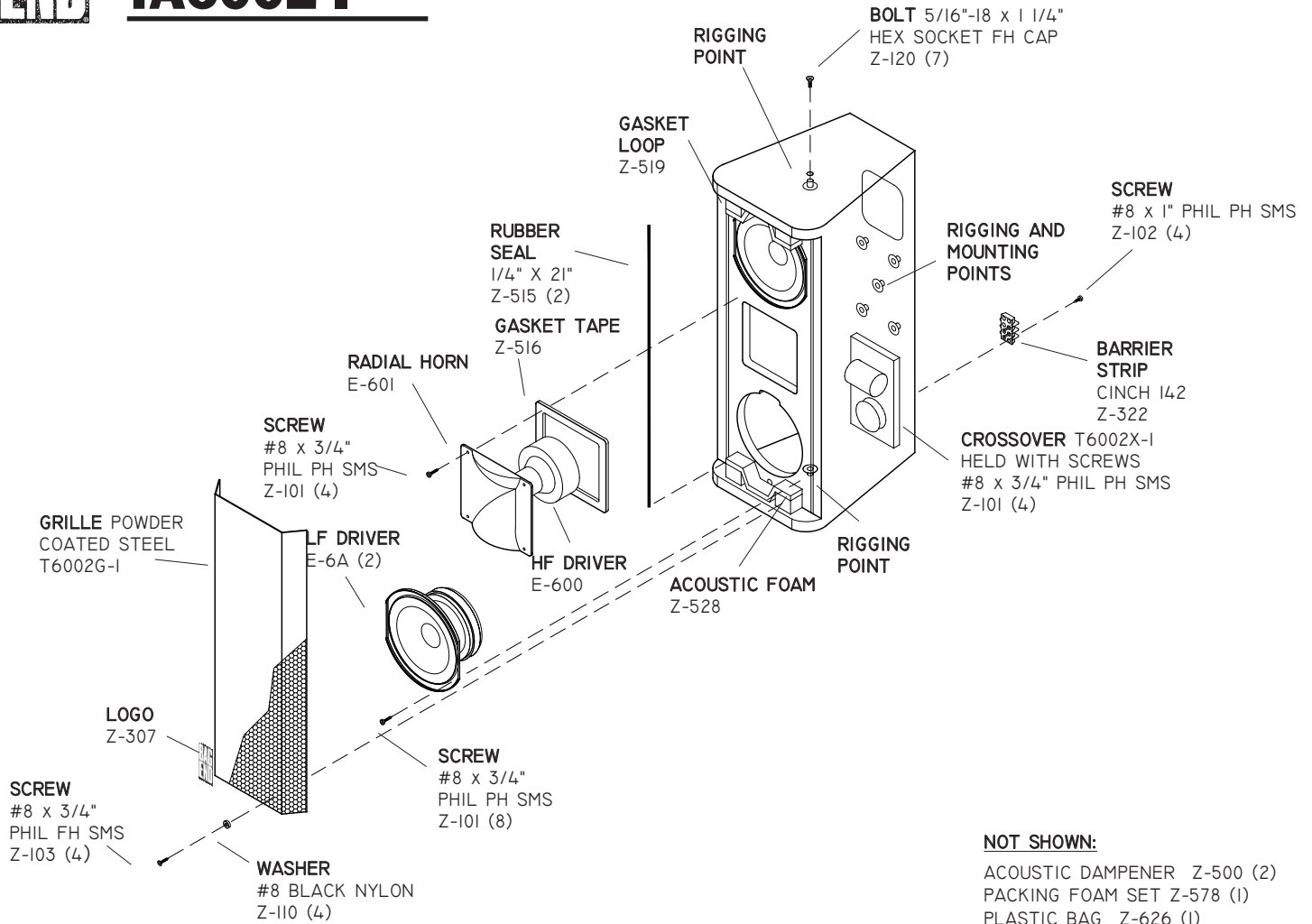

SYSTEM SCHEMATIC

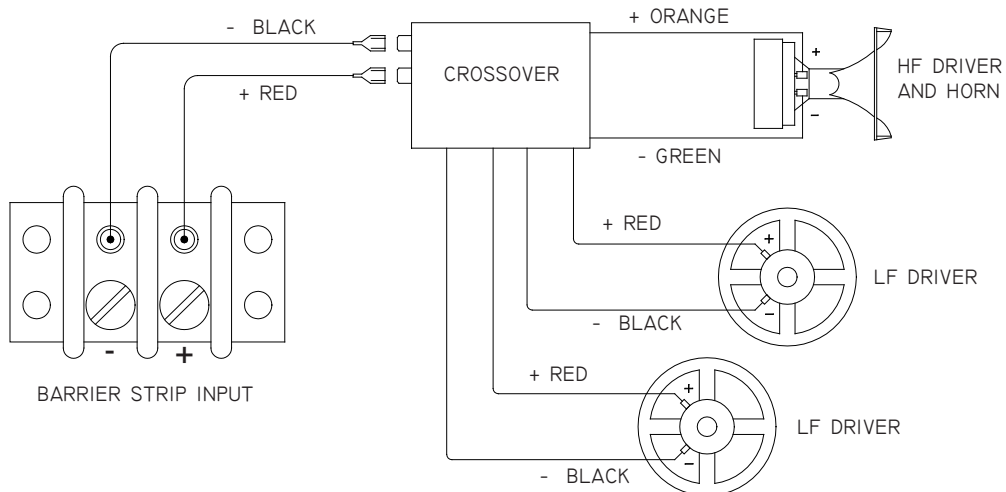

BAG END

TA6002-I TIME-ALIGN®

Rigging Points

⊕ = Center of Gravity

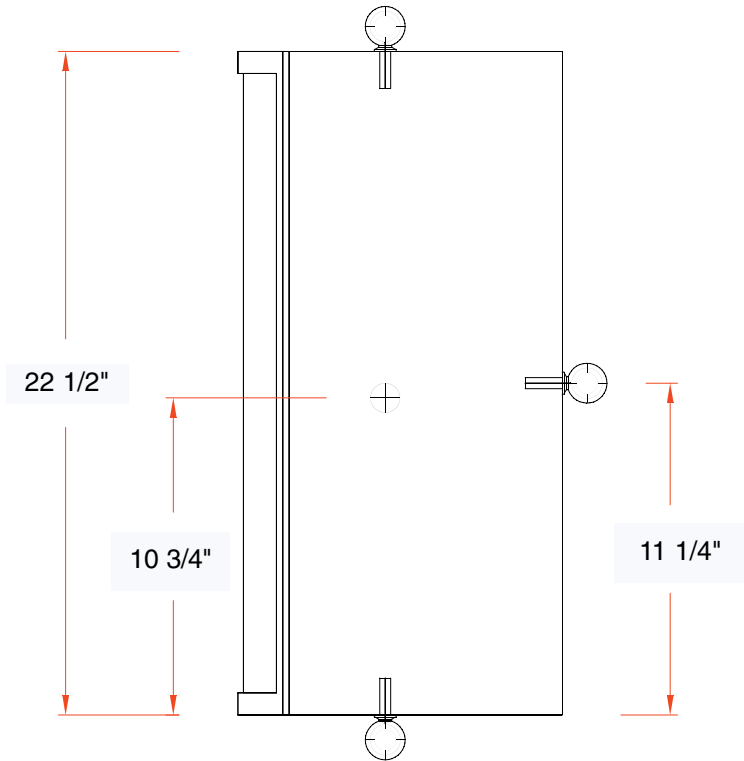

Side View

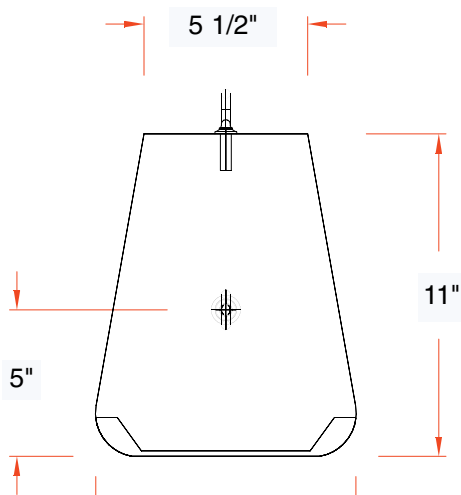
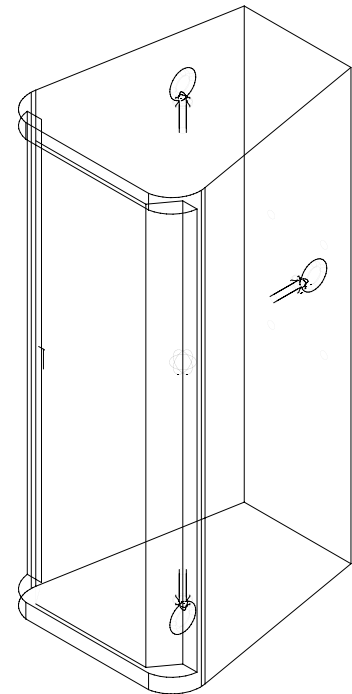

Top View

Warning:

Mounting and rigging loudspeakers require experienced professionals. Improperly installed loudspeakers can result in property damage, personal injury, death and/or liability to the installing contractor.

F6 option includes flypoints as shown, 3 x 5/16"-18 forged shoulder eyebolts.

BAG END Loudspeakers
22N272 Pepper Road
Lake Barrington, Illinois
60010 USA
Voice 847 382 4550
Fax 847 382 4551
www.bagend.com

